



BERNAL HEIGHTS EAST SLOPE BUILDING GUIDELINES

Prepared by the:

BERNAL HEIGHTS
EAST SLOPE
PRESERVATION
COMMITTEE

October 1986

Accepted by the
San Francisco Planning Commission
November 13, 1986

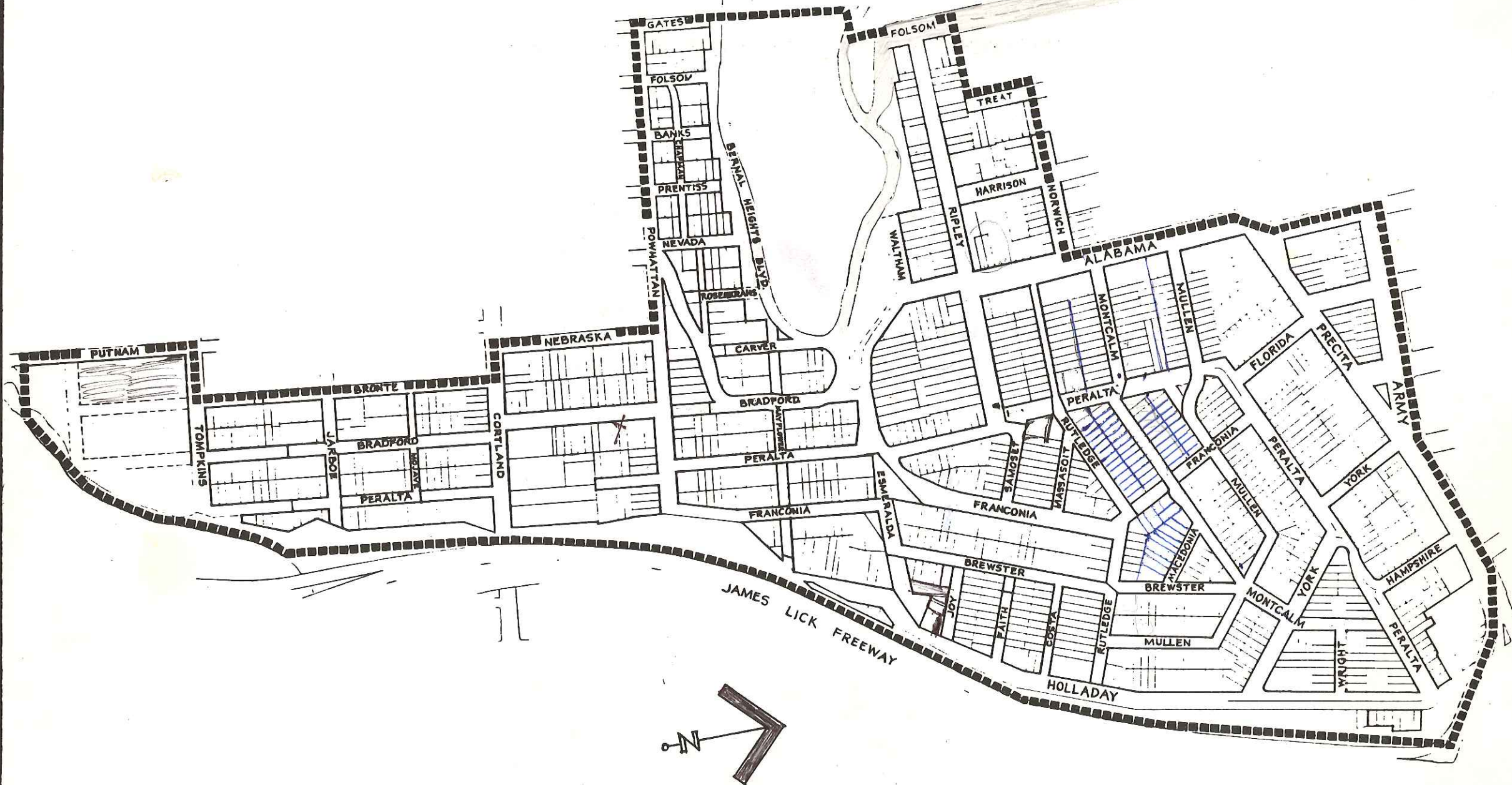

BERNAL HEIGHTS EAST SLOPE

October 1986

East Slope Preservation Committee Members

Tony Ambrot
Steve Antonaros
Barbara Badgett
Bart Booth
Patricia Cacio
Matt Camporeale
Bill Cassidy
Sabina Cesar
Christina Colt
Robert Colt
Toby Coribero
Jeff Cretcher
Serenma De Bellis
Kathy Debkoski
Robert Dedman
Carol Deutch
Judy Drummond
Lee Egger
Nedra Everett
Tom Everett
Gregory Frazier
Richard Freeman
Don Hansen
Bob Harmon

Ann Henry
Betty Kilich
Joe Kirrane
Jill Kjompedahl
Luz Lagajit
Peter Lerke
Howard Malloy
Roosevelt Miller
Terry Milne
Tim Molinare
Fred Nietz
Maxine Nietz
Joan Ovenden
Norma Planiczka
Walt Planiczka
Dassy Shellenburger
Leslie Simon
Art Stamps
Allen Statler
Irene Thompson
Lorraine Vail
George Wynns
Jill Wynns

Bernal Heights Community Foundation
Mike Reed

Dept. of City Planning
Jon Hussey

Supervisor Nancy Walker's Office
Eric Shapiro
Charles Starbuck

The East Slope of Bernal Heights occupies a special place in the hearts of its residents. To those who would join us, we extend a cordial welcome and ask that they develop their properties and create their homes in such a way as to preserve and enhance the qualities inherent to this special place. It is anticipated that these guidelines will encourage builders to design homes responsive to the unique character found on the East Slope.

Acknowledgement and Thanks

We are indebted to members of the Northwest Bernal Block Club and the Elsie Street Plan developed by them in 1978. These guidelines were derived from and inspired by their work. In most sections contained herein, the words are theirs. Were it not for their groundwork, our efforts would have been infinitely more arduous.

We also wish to express gratitude to the Vanguard Public Foundation for its financial support.

It is our hope that the following guidelines will serve as an aid to designers and builders of homes on Bernal Heights' East Slope. These building guidelines are the result of the community's desire to see the special qualities of the East Slope preserved and enhanced by any new development. The Bernal Heights East Slope is a special neighborhood and the qualities that make it that way are cherished by all those whose commitment to seeing them preserved has produced these building guidelines.

The history of the East Slope has been one of benign neglect by the City of San Francisco, however, while dirt roads and undeveloped hillsides have given the East Slope its rural character, the lack of roads and services has periodically presented real danger to the residents.

Much recent development is not only inconsistent but often at odds with the smaller scale existing structures. As a result, the East Slope's rural characteristics rapidly are disappearing along with views, open space and trees. Some new buildings have created "canyons" blocking sunlight and presenting building facades, which are all copies of a single undistinguished design.

In preparing these guidelines we have made a thorough inventory of present housing stock, vacant lots, open spaces, public areas, and streets, both developed and undeveloped.

Predominant architectural components have been examined along with the relationship of individual buildings to their lots and their immediate neighbors. These guidelines are an effort to retain the spirit of our neighborhood and to establish criteria for new housing design that will ensure, as much as possible, the continued existence of the East Slope's unique character.

It is impossible to be fully comprehensive since nearly each vacant lot has its own peculiarities. There can be no guarantee that if every guideline is met the resulting structure will be an architectural jewel. However, we hope these guidelines will point the way toward minimizing monotony and enhancing the visual appeal of new housing.

We have tried very hard to make the guidelines prescriptive rather than restrictive. The intent is not to induce dull uniformity but rather to encourage inventive diversity while conforming to the patterns of development which have made Bernal Heights as humanly scaled as it is today.

In an interview recorded earlier in 1986, architect Hugh Jacobsen, a four-time winner of the National Honor Award of the American Institute of Architects is quoted as saying:

"From the beginning, I've looked at all architecture as a matter of good manners, being part of the whole street, being part of the fabric of the city. Good architecture, rather than beating its chest or shouting at neighbors, behaves like a well-mannered lady. There is politeness in every great city— Florence, Rome, and especially Paris. The streets have continuity but each building also has its own individuality. The buildings are at once proud and humane, standing strong in their mutual respect."

Certainly San Francisco is considered one of the great cities of the world. We fervently hope that newcomers to the East Slope, as part of a great city, will be architecturally polite so that we, the old and the new, can stand strong in our mutual respect.

DESIGN GUIDELINES

The design guidelines are broken down as follows:

	Page
1. 9'-0" CURB CUT • SINGLE CAR GARAGE DOOR _____	4
2. LANDSCAPING • FRONT YARD SETBACKS • STREET TREES _____	6
3. ENTRY TREATMENT _____	9
4. BUILDING BULK AND ARCHITECTURAL MASSING _____	12
5. SIDEYARDS _____	17
6. ROOF TREATMENT/STEP WITH SLOPE ALONG STREET _____	21
7. FACADE ELEMENTS _____	24
8. COLORS AND MATERIALS _____	30

9'-0" CURB CUT • SINGLE CAR GARAGE DOOR

PROBLEM:

New construction which has no provision for landscaping at the front ignores the importance of greenery in enlivening the streetscape.

RULE:

Garage doors shall be limited to a 10'-0" width. Curb cuts shall be 9'-0" and placed so as to create a 16'-0" curb space within the 25'-0" width of the lot to provide one full parking space on the street. In addition, the garage door shall be placed a minimum of 16'-0" from the inside edge of the sidewalk, so as to provide one additional parking place per resident in the driveway. Of course, there will also be the usual City-required enclosed garage. These garages can be designed to accommodate two cars inside.

INTENT

To maximize the number of parking spaces available on the street; and to provide two off-street parking places per house. A 9' curb cut provides increased opportunity for street parking and the single car garage door allows for greater flexibility in building design.

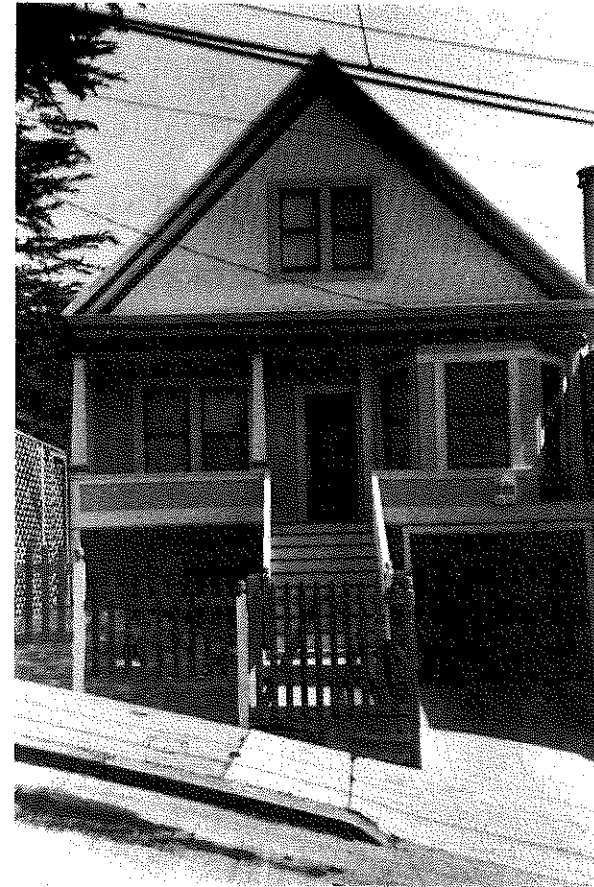

Actual situation of three parking spaces per residence.

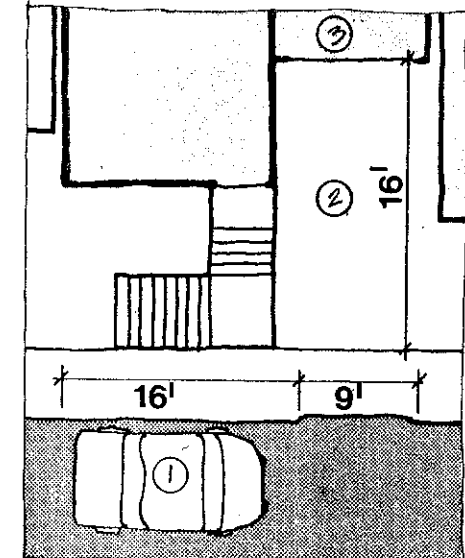

Single car entry: space for one car on street in front of each 25'-0" lot—street parking maximized.



Actual Situation

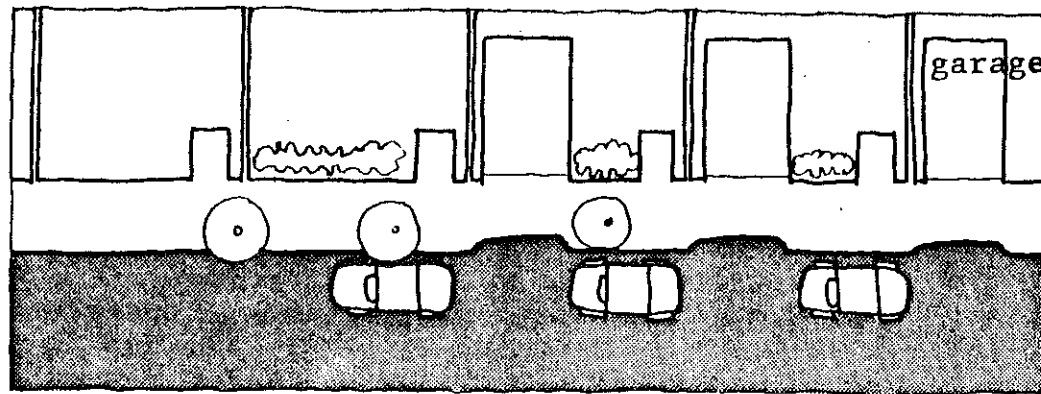

Plan of scheme

Double car entry: no full on-street curb space—street parking eliminated.

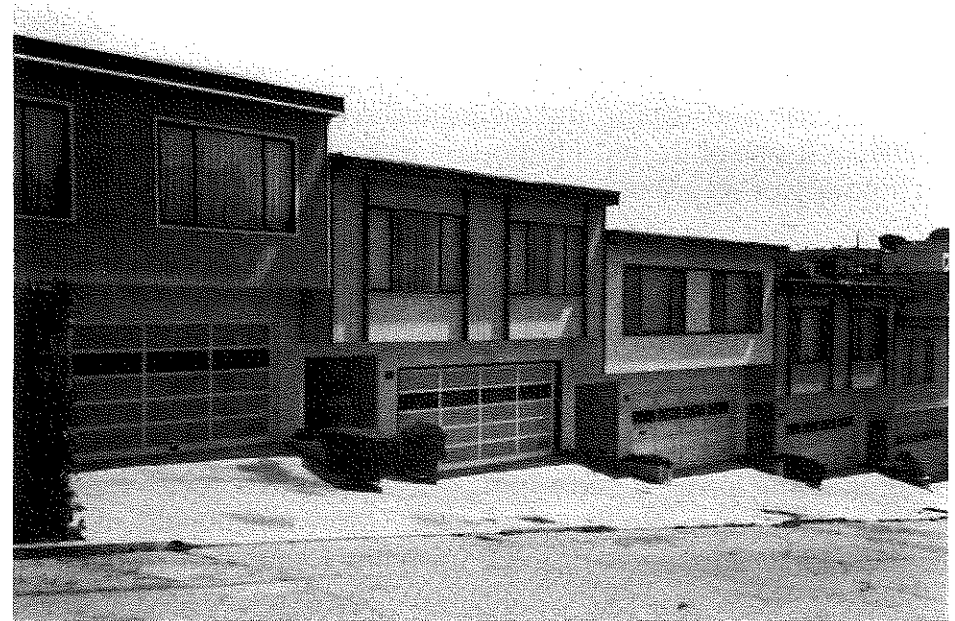

Actual Situation

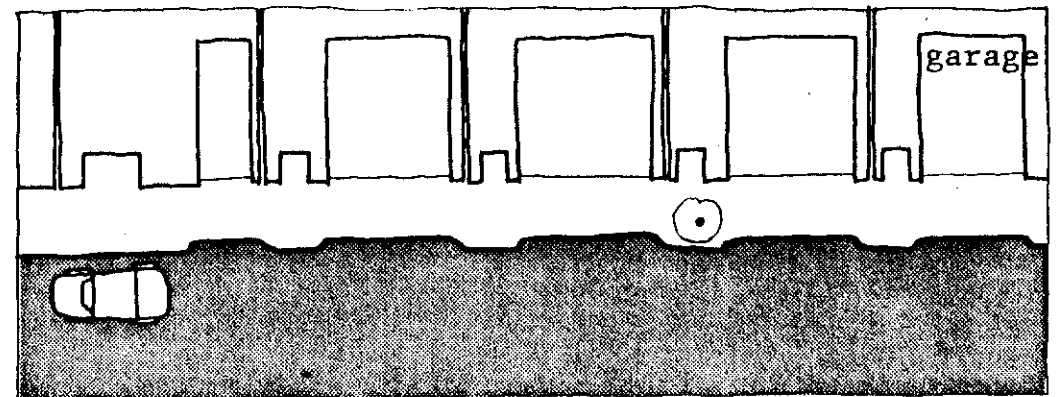

Plan of scheme

LANDSCAPING • FRONT YARD SETBACKS • STREET TREES

It is recognized that landscaping and the inclusion of street trees in residential areas is one of the most important factors in providing an area with intimacy of scale and character.

LANDSCAPING

Greenery helps to provide privacy without barriers, soft edges in the built environment, and a reminder of our relationship to the earth. The fantastic geometry of biology combines well with the more rigid geometry of building forms. Landscaping can be used as a device for bringing color and texture into the urban scene. More functionally, if properly planned, it can serve to disguise unsightly foundation work and the like.

FRONT YARD SETBACKS

Front yard setbacks pave the way towards increased opportunities for landscaping and variety of entry approaches. With structures placed back from the property line, a feeling of openness is maintained and the access of light and air to the street is maximized. When a house is placed up to the sidewalk on sloped terrain, all sense of the topography of the lot is lost.

STREET TREES

"The livability, amenity and character of residential areas are greatly enhanced by trees, more so than by any other single element."

(Fundamental Principles for Neighborhood Environment #1, *The Urban Design Plan for the Comprehensive Plan of San Francisco*, May 1971.) Street trees create rich textured patterns of light and reflection on the sidewalk, are pleasant to walk under, and provide places for birds to roost. They reflect the passage of time as they change with the seasons, connecting us to nature's timetable.

RULE:

Front Building Setbacks are essential, and must be established by:

1. conforming to existing setbacks on adjacent or near-adjacent houses;
2. averaging when lot in question is between two existing structures;
3. topographic considerations.



Example of a well-landscaped front yard.

Examples of buildings built up to the property line with little or no provision for front landscaping.

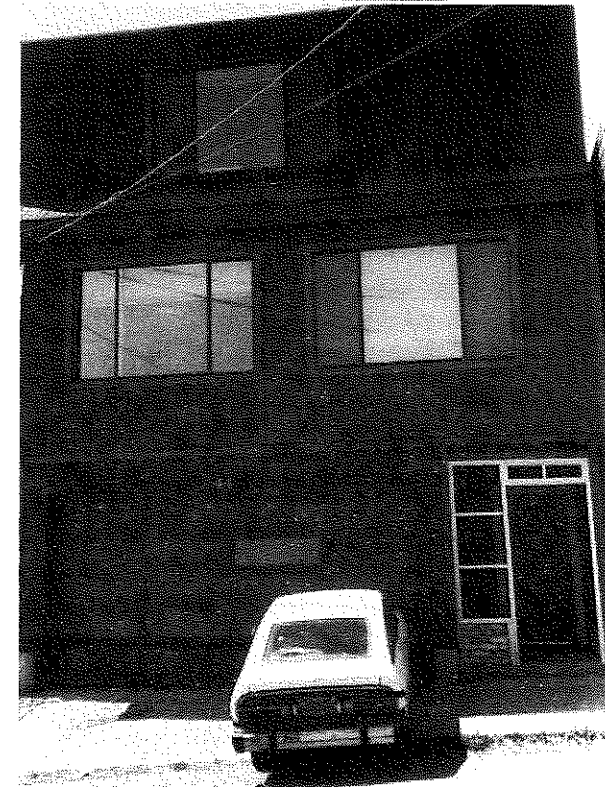

RULE:

50% of the Front Building Setback area (not including the driveway up to the garage) shall have provision for landscaping (i.e. trees, shrubs, flower beds, ground cover, vines, etc.)

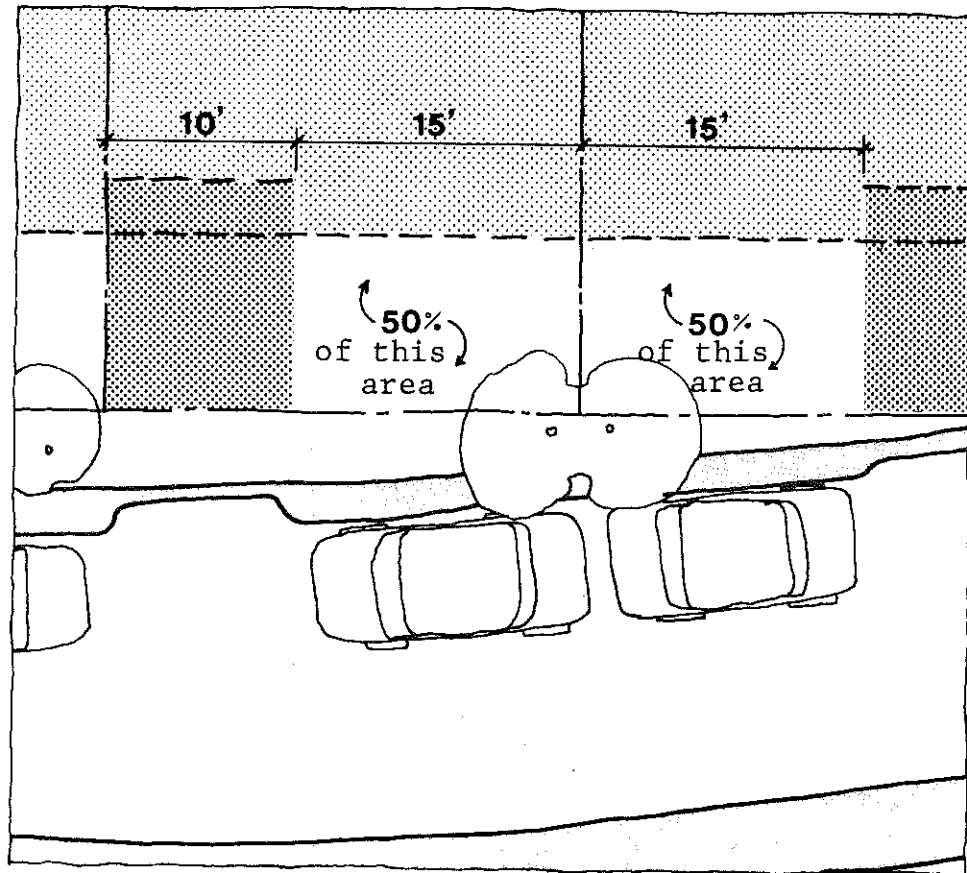

RULE:

One street tree shall be planted at the time of construction in front of each lot within the 40'-0" wide street right-of-way, and close to the front property line. Trees shall be at least 15 gallon size.



ENTRY TREATMENT

"Entrances create a transition between the 'outside'—the public world—and some less public inner world.

"...What matters most is that the transition exists as an actual physical place, between the outside and the inside, and that the view, and sounds, and light, and surface which you walk on change as you pass through the place. It is the physical changes ... which create the transition." (112 Entrance Transition, *A Pattern Language*, Christopher Alexander, Sara Ishikawa, Murry Silverstein: Oxford University Press 1977).

PROBLEM:

We are concerned with the way in which entries are handled. There are many approaches to entries: however, they can basically be broken down

into two categories: those which are essentially holes in the wall of the facade and those which are separated from the street by some sort of intermediary transition space. All too often in new construction, hole-in-the-wall doorways are resorted to.

RULE:

Make the entry of the house something special—a celebration—more than just a front door. Create a transition between the street and the doorway. Give special attention to the treatment of the framing of the opening itself.

The following examples and their descriptions illustrate our intent.

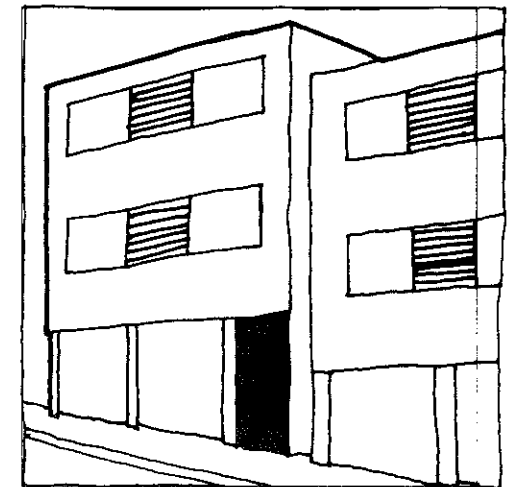
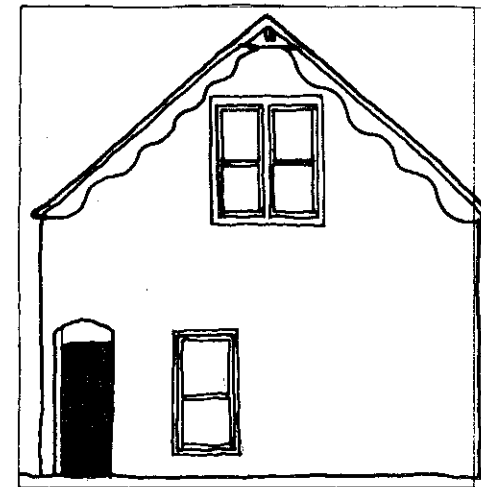
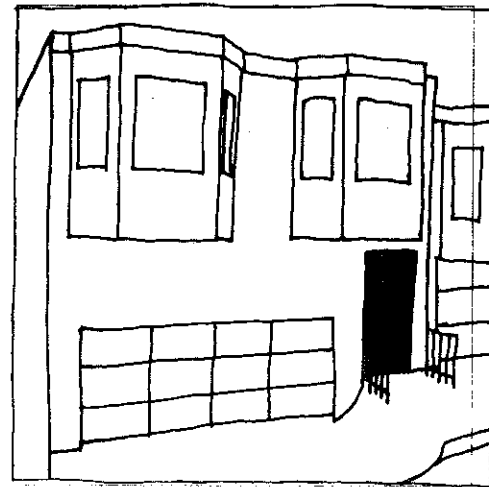
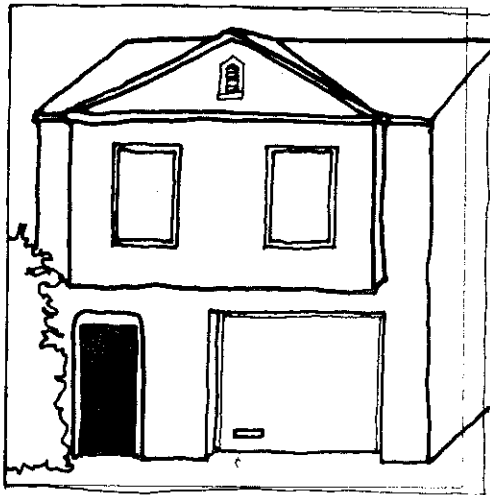

These entries all have the same problem: they are basically holes in the wall. There is no transition place; landscaping is avoided, and no special treatment has been provided at the threshold.

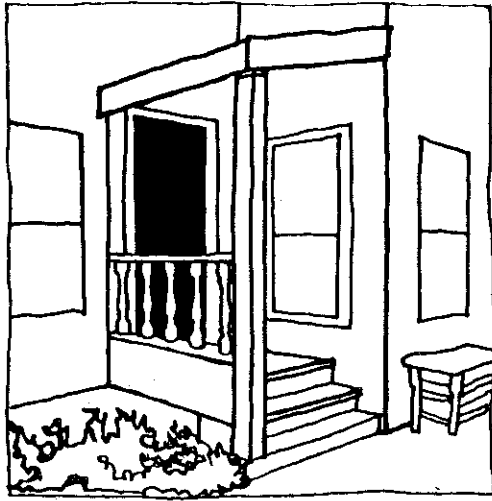

1. This entry is highlighted with a canopy overhead and an embellished handrail. Despite the fact that one essentially enters on grade, a forced change of level takes notice of the importance of its function. A touch of landscape softens the approach. A sitting place by the entry harks back to a time of stoops and street watching. The difference between the brightness of unfiltered sunlight and the subdued light of the interior is bridged by the lowered light level under the overhang.

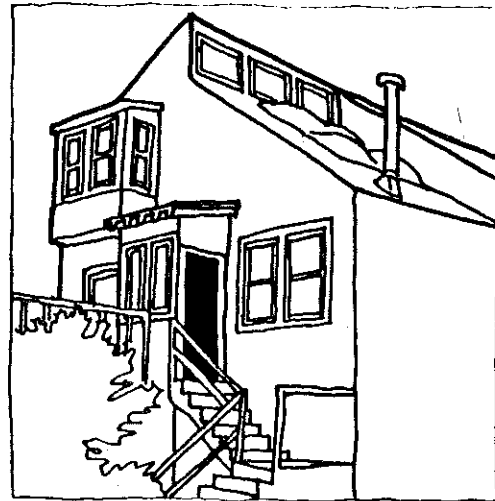

2. This entry combines level changes, directional changes and textural changes, in the form of varied foliage, to make its statement. The front door is set in a lighted vestibule that is welcoming. The window adjacent is a friendly indicator to the visitor of what is to come as it gives the occupants a sneak preview of what they'll find on their doorstep.



3. This entry comes straight off the street and yet avoids merely being a hole in the wall by rising to accentuate the transition and by being framed and trimmed out in a special way.
In addition, the double width steps at the base unify the building's entry with its sideyard access.

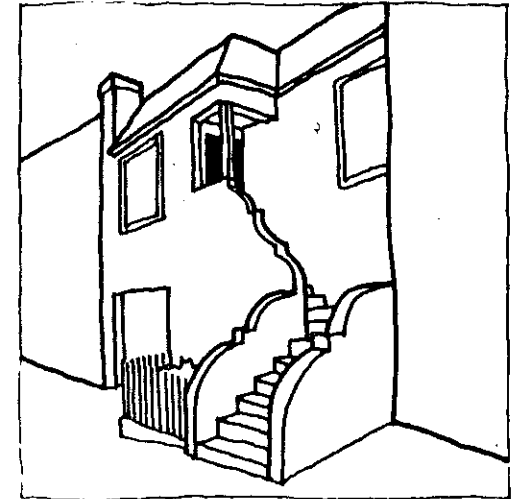

4. This entryway incorporates many positive features: change of level, change of direction, change of texture and light. Perhaps most significant, however, in this example is the simple but whimsical treatment given to the structural elements used to frame the stairway. Everything points up the unique function of the entry in the hierarchy of the building.

FENCE TREATMENT

For a person on the street it is far more pleasant to be allowed a glimpse of the space beyond a fence or wall than to be confronted with a solid barrier.

RULE:

Fences or walls which enclose a lot or a portion of a lot, which run parallel to the property line on the street side, and are not structural portions of the building or the stair leading to it, shall not be completely solid at eye level.

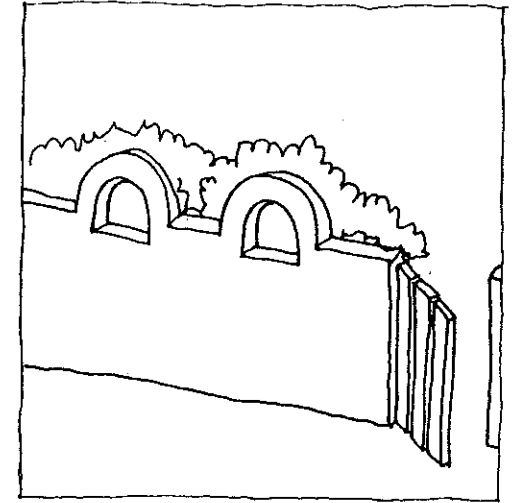
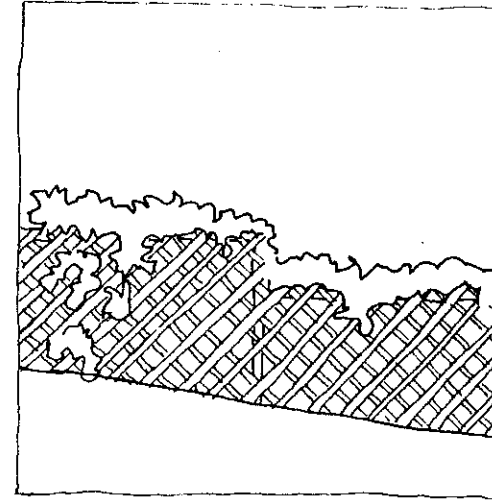

Suggestions for fence treatments.

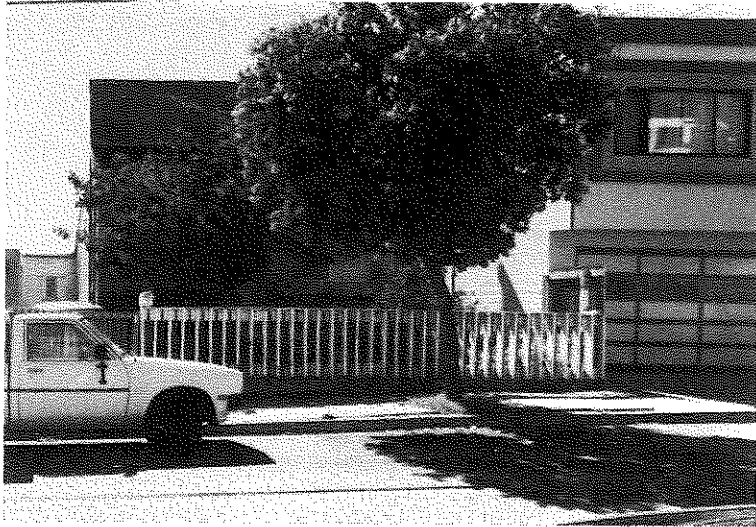

Fences which meet guideline standards.

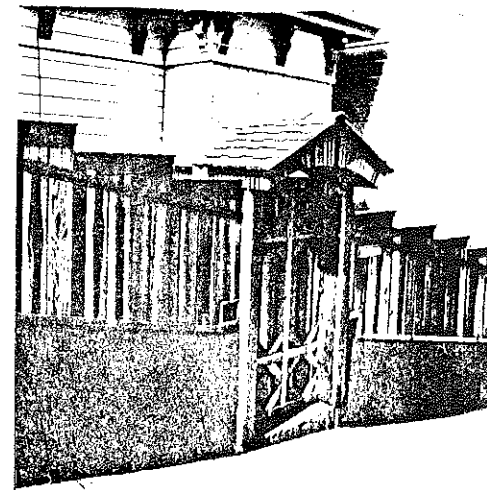

Fences which do not meet guideline standards.

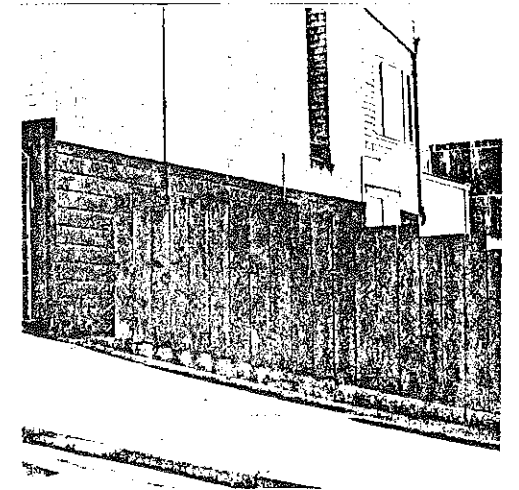

BUILDING BULK & ARCHITECTURAL MASSING

It has been recognized by the City of San Francisco, as well as by the residents of Bernal Heights, that the character of new construction is destined to have a long term effect on the nature of our city and its neighborhoods. The Urban Design Element of the Comprehensive Plan for San Francisco supposedly includes design principles, which provide guidance to potential developers, in order to assure that new development be compatible with the delicate scale and character of the existing houses in hillside residential areas. If planning principles are to be judged by the success of the products, those set forth thus far have failed.

On Bernal Heights there are still many vacant lots, and in the last few years, development pressure has skyrocketed. The new "vernacular form" is the maximum-building-envelope-shoebox. The box presents an image more reminiscent of apartment units than of a house form. It is a solution without a context, which isolates itself from its setting by not acknowledging its neighbors, its views, its orientation towards light and air paths. It is a non-specific plan which developers scatter around the city wherever open lots occur.

When the box first appeared, the dull streetscape that it presented drew a lot of criticism. People called for a form more in keeping with the spirit of San Francisco's architecture. The bays and minuscule balconies which were tacked on have proven to be no more than band-aid solutions. The dressed-up box has not fooled anyone. Its token accoutrements, rather than being a part of the organic whole, are elements that deny the overall integrity of the building.



Older houses



Newer "shoebox" houses

PROBLEM:

Around the East Slope of Bernal Heights the remaining open lots are steeply sloping. Consequently, the main problem here is one of heights and architectural massing.

"The downhill slopes are particularly problematic because most house designs provide living space only above the street plane, with void space below. This void space is either open, with a stilt structure supporting the house, or closed, with blank walls to the ground. Either situation is unsightly and wasteful. These void spaces often comprise more cubic footage than the residence itself, thereby doubling its apparent bulk. Older structures tend to have much smaller void spaces under them and therefore much less bulk. New residences should have living spaces as close to the ground as possible. This looks better from below, reduces bulk, and makes rear yards more accessible." ("Residential Development On or Near the Top of Hills" from Policies from San Francisco Department of City Planning Documents.)

Most older houses on the East Slope are three stories tall (this includes basement, first floor and attic) but only approximately 25 feet high. They also exhibit strongly individualized house forms. Because of current interior space requirements and a city-mandated covered garage, buildings of three full stories are anticipated. The massing problems for prospective builders is to develop shapes which stack in such a way that the new houses meld with the existing ones when they occur side by side.

The massing problem is one of relating a building to its topography. Unless the private open spaces (front, side and rear yards) surrounding a house are easily accessible from prime living areas they tend not to be used. If a building does not step with the slope it loses its relationship to the ground.

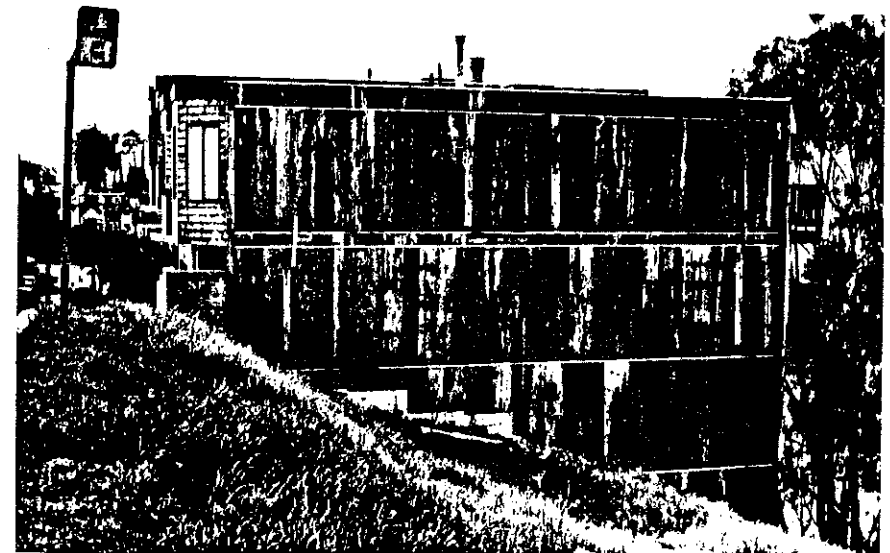

Dressed up box on Elsie Street. Note proportions of token bays and tacked-on balconies at rear which are too small to be functional. Imagine how any building placed next to it would be overpowered by its bulk.

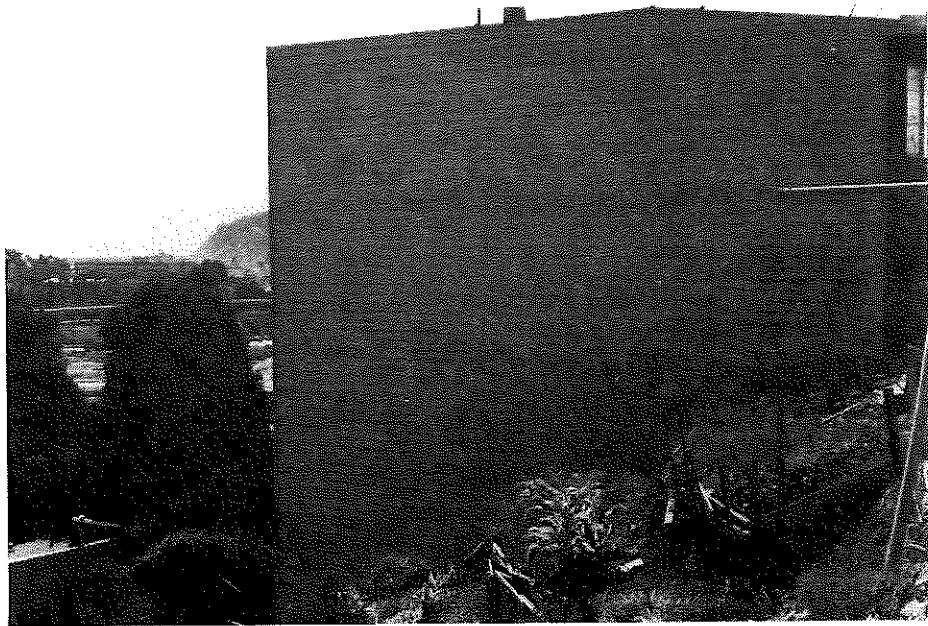

Towering rear elevation—note dwarfed backyards

The new juxtaposed
against the old
should blend
better than this.



INTENT

Our objectives in the Building Bulk Guidelines are neatly summed up in already existing City Planning Policies. To quote from the Urban Design Element of the Master Plan, our intent is to:

1. Minimize the blockage of sun from adjacent downhill properties;
2. Lower the first level of occupancy to a level enabling ready access to rear yard open space;
3. Deter the possibilities of visually dominant buildings with blank and uninteresting exteriors which do not relate well to surrounding development;
4. Promote harmony in the visual relationships and transitions between new and older buildings; and,
5. Encourage the construction of buildings which meet the ground and reflect the slope of the hill.

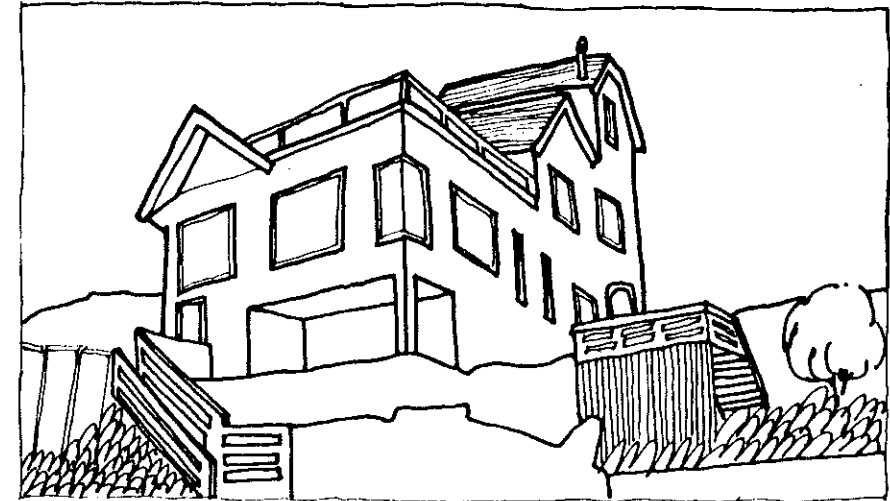

Building on Bonview St.—stepping up the slope.

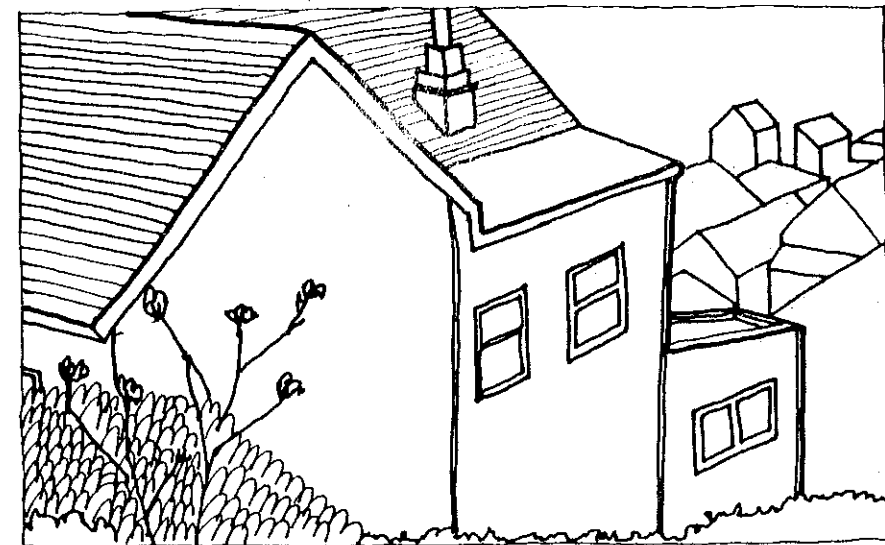

Building on Elsie St.—stepping down the slope.

STRATEGY

1. Step the building with the slope.
2. Break up the overall massing into articulated architectural pieces.
3. Break up solid plane of the facade.
4. Require at least a partial 4'-0" wide sideyard on one side of the lot (see Sideyard Design Guideline.).
5. Diminish height of the rear portion of the building.
6. Require pitched or usable flat roofs (See Roof Design Guidelines.).

As with these guidelines, this one is dependent upon the implementation of all the others. Should there be amendments, particularly to the front and rear setback rules, these height limits would have to be revised.

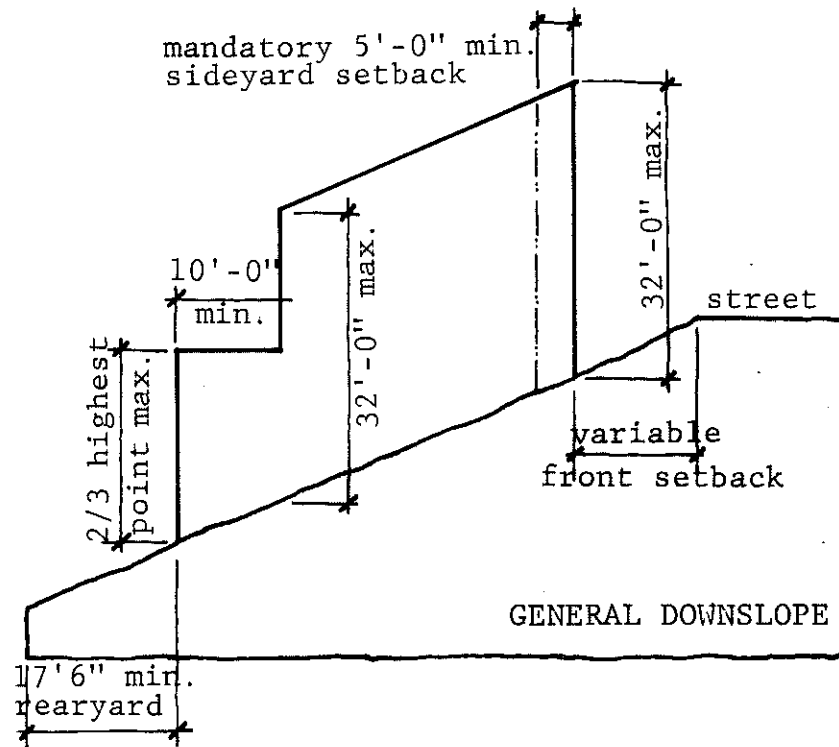

RULE:

Step the building with the slope.

Building shall not exceed 32'-0" from any point on natural grade. This height shall be measured to the average height of a pitched roof or to the highest point of a flat roof.

In addition, no point of the last 10'-0" of depth of the building may exceed 2/3 the height of the highest point of the structure. Highest point, once again, is defined as the average height of the pitch on a sloped roof or the highest point of a flat roof.

At the rear, a minimum 17'-6" rearyard is required for a 70'-0" deep lot and 25'-0" for a 100'-0" lot.

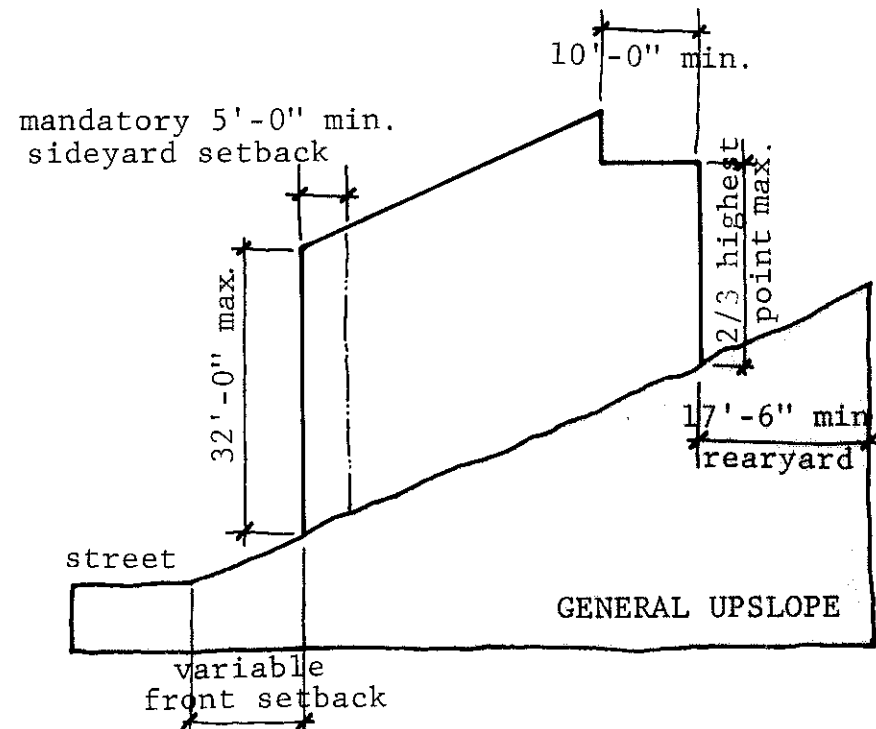

SIDEYARDS

After a long study of the pros and cons of requiring a sideyard on one side of the lot versus building lot line to lot line, it was determined that the inclusion of a sideyard is an essential ingredient in reaching our design objectives.

This decision is consistent with our interest in insuring that new construction respect the existing scale and character of the neighborhood.

INTENT

To help reduce the building bulk:

1. by breaking up the solid-wall effect on the street; and
2. by providing increased opportunities for architectural articulation.

To provide access to rearyards:

3. for firefighters; and,
4. for garden work, children with muddy feet, and the like.

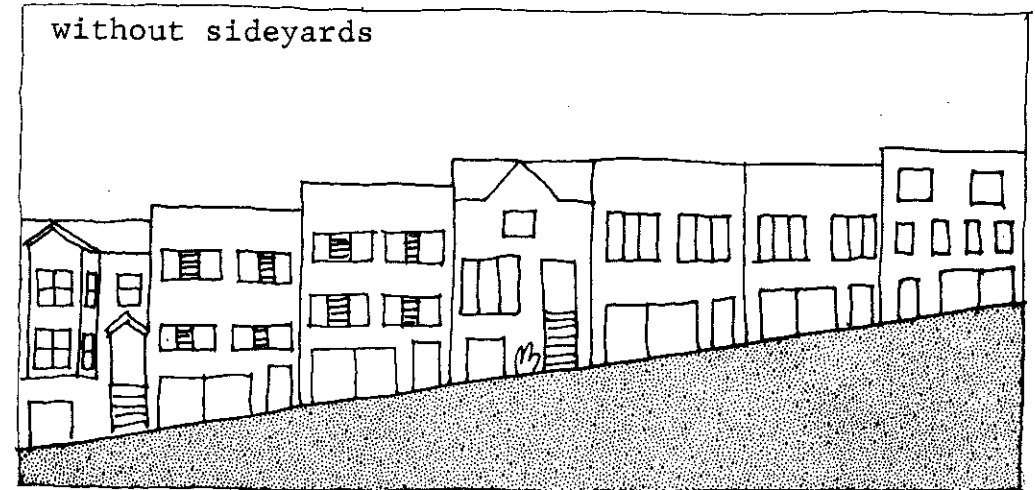

To get light, sun, air and views into and out of buildings;

5. by the use of bays on the side; and,
6. by providing a third wall on which to place windows.

To create a more diverse street character;

7. by allowing views to the east (towards the Bay) and views to the West (toward Bernal Hill) for pedestrians walking along the block.
8. by increasing possible locations for landscaping;
9. by maintaining the existing neighborhood character; and,
10. by increasing the variety of possible entry approaches.

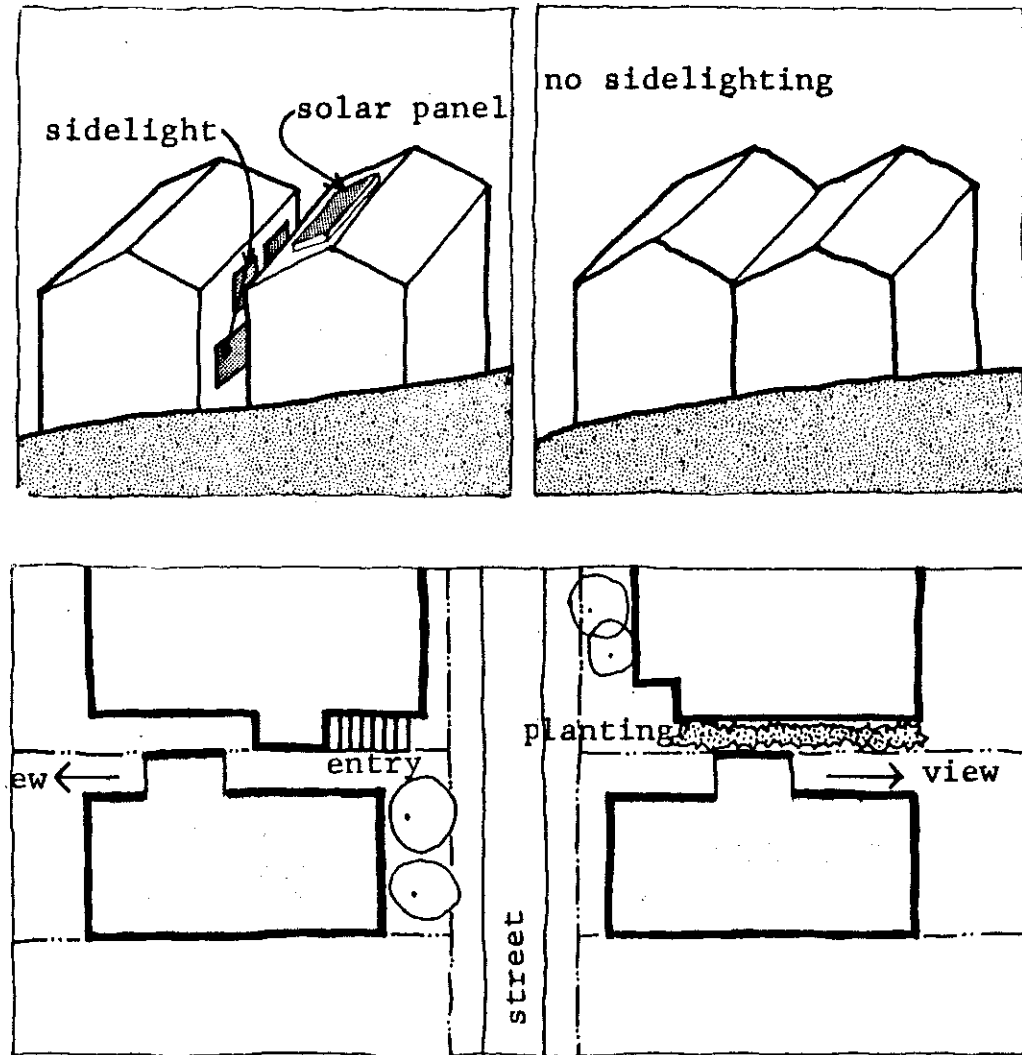

RULE:

A four foot wide sideyard is required on one side of each 25 foot lot. The first five feet back from the street facade shall be left completely open. Beyond that, two of the four additional sideyard zones must be left open. (Zone explanation follows.)

SIDEYARD ZONES

The required 4-foot sideyard is divided into five zones:

Zone 1 runs the full height of the building for a depth of five feet from the street facade. No part of the building shall project into this zone.

Zone 2 is the bottom from directly behind zone 1.

Zone 3 is the top front directly behind zone 1. It must be at least 7'-6" above grade for its entire depth.

Zone 4 is the bottom rear directly behind zone 2 and extending to the rear of the building.

Zone 5 is the top rear directly behind zone 3 and extending to the rear of the building. It must be at least 7'-6" above grade for its entire length.

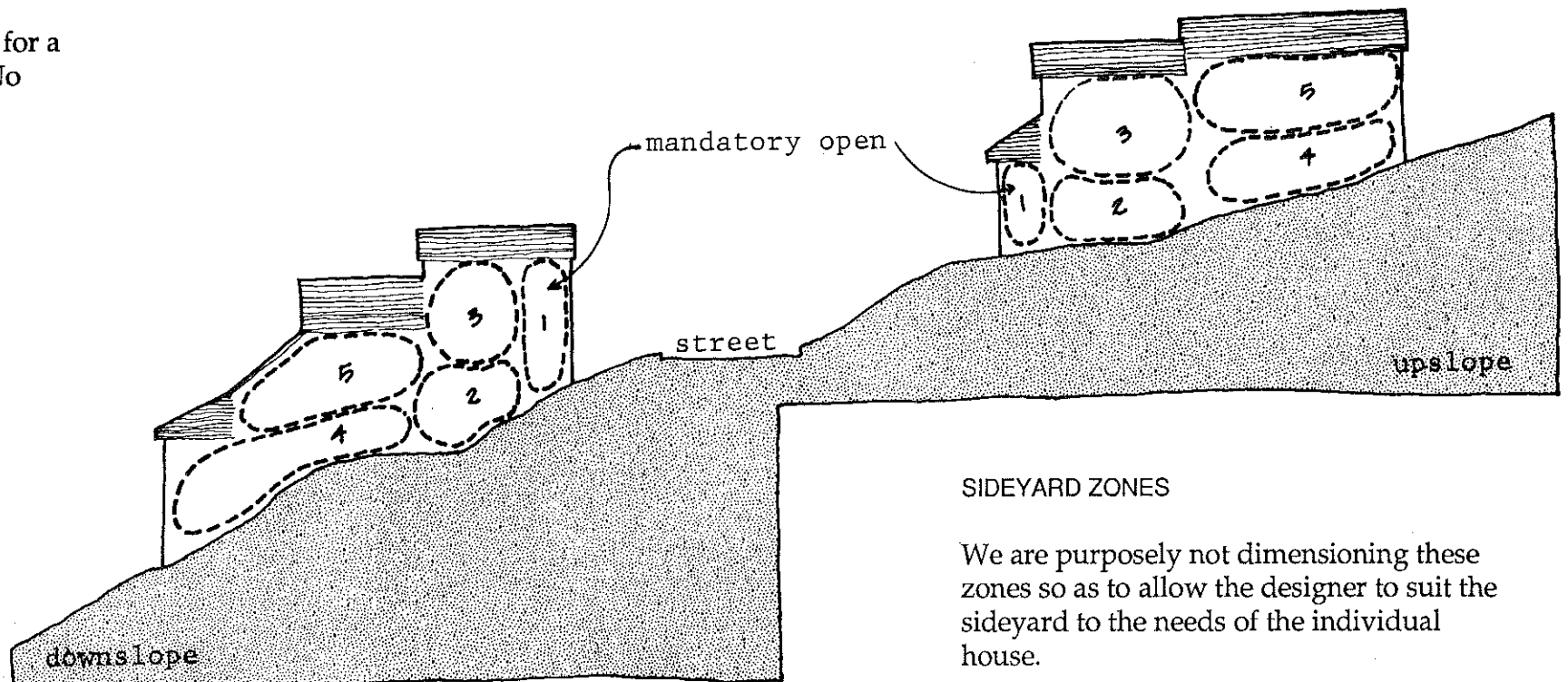

Examples of existing sideyards and how they fit the “zone” pattern:



Sideyard for pedestrian views.



Sideyard for planting.

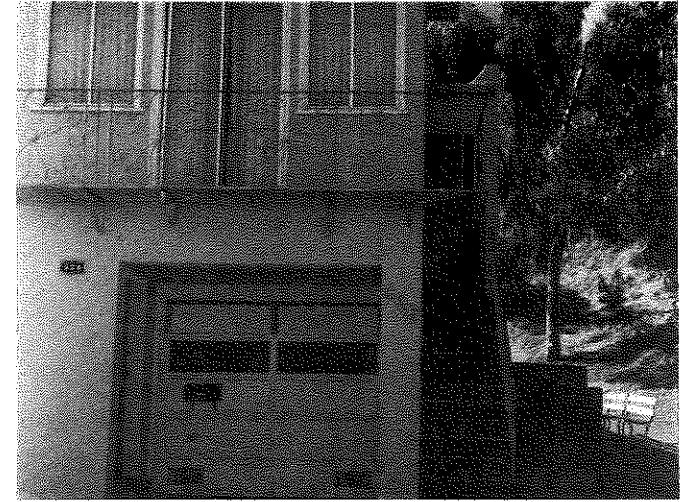

Sideyard for entry.

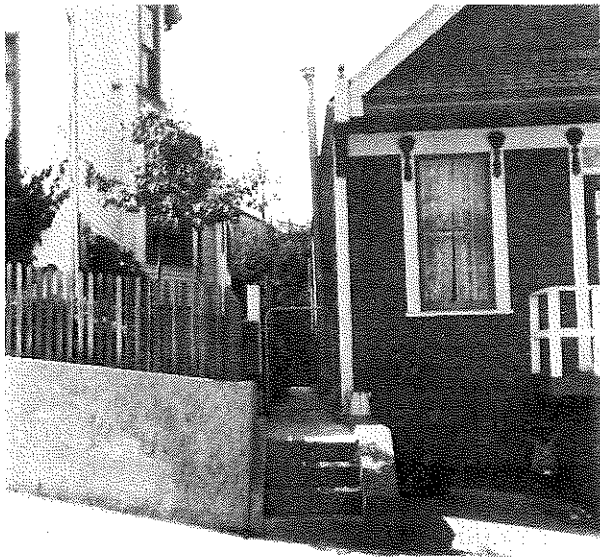

Sideyard for light to middle.



Sideyard for access to rear.

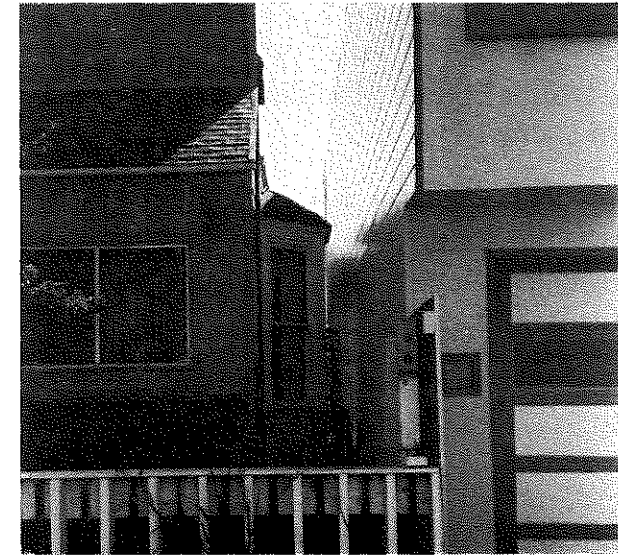

Sideyard as combination of light to middle and access to rear.

ROOF TREATMENT • STEP WITH SLOPE ALONG STREET

ROOF TREATMENT

"A vast part of the earth's surface in a town consists of roofs. Couple this with the fact that the total area of a town which can be exposed to the sun is finite, and you will realize that it is natural, and indeed essential, to make roofs which take advantage of the sun and the air." (From *A Pattern Language*, page 576, Christopher Alexander, Sara Ishikawa, Murray Silverstein: Oxford University Press, 1977)

INTENT

Usable flat roofs:

1. take good advantage of sun and air;
2. provide additional space on lots which, because of their small size, are limited in their possibilities for outdoor spaces;
3. provide a direct flow between indoor and outdoor spaces for rooms above ground level; and,
4. increase possibilities for landscaping.

Pitched roofs:

1. provide opportunities for sidelighting through the use of dormers and skylights;
2. are a surface for easily mounting solar collector panels if the pitch is in the range of 38 degrees to 48 degrees;
3. reduce the visual bulk of the structure;
4. allow houses further up the slope to maintain glimpses of their views on either side of the ridge line;
5. form a diversified skyline from the street;
6. give a more 3-dimensional quality to the building than a flat roof does; and,
7. are compatible with the housing stock in the surrounding neighborhood.

PROBLEM:

Unusable flat roofs:

1. tend to look blocky from the street;
2. obscure views;
3. present a view of unsightly tar and gravel planes with plumbing and mechanical systems randomly strewn around for residences higher up on the slope; and,
4. are inconsistent with the housing stock which presently characterizes the neighborhood.

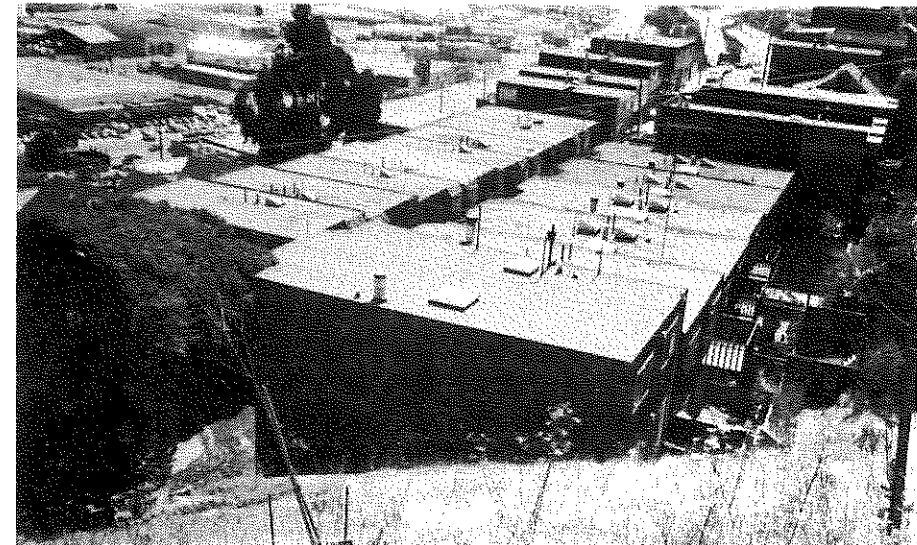

RULE:

Any roof which is not pitched at a ratio of at least one in four must be designed and surfaced so as to be usable.

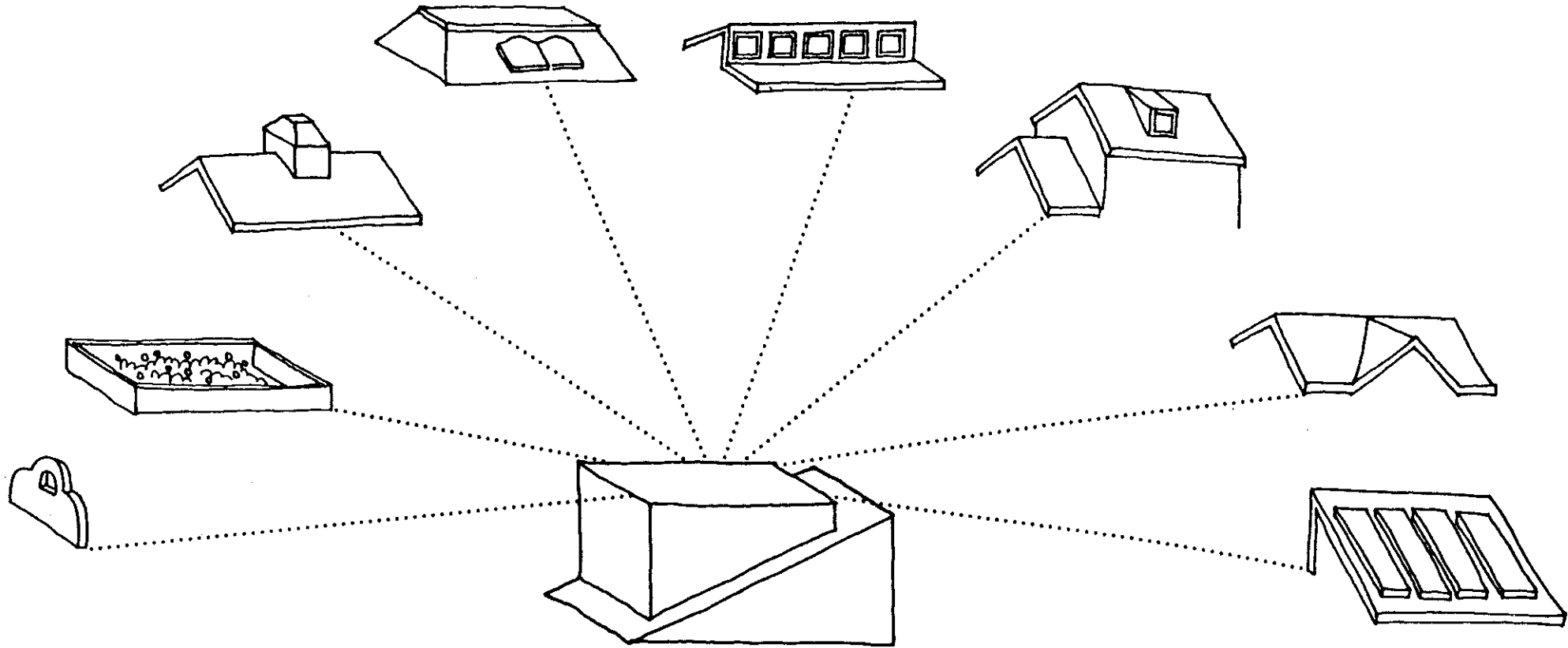

"...make it possible to walk out to the roof garden from an interior room without climbing special stairs. It is far more comfortable to walk straight out onto a roof and feel the comfort of part of the building behind and to one side of you, than it is to climb up to a place you cannot see." (From A Pattern Language, page 577, Christopher Alexander, Sara Ishikawa, Murray Silverstein: Oxford University Press, 1977)

RULE:

Any flat roof must be accessible from a prime living space without the necessity of climbing a special set of stairs to reach it.

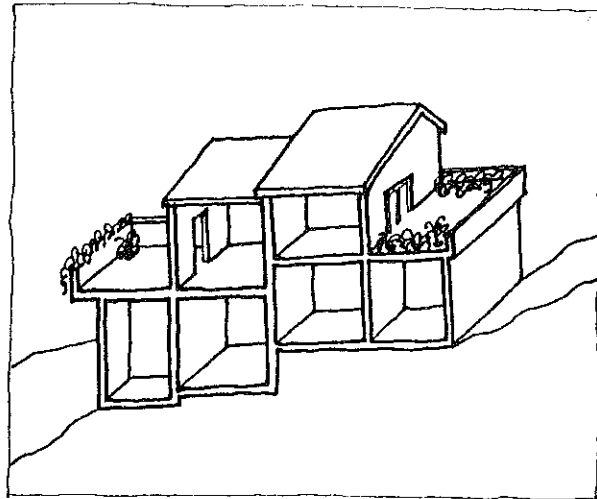

STEP WITH SLOPE ALONG STREET

One of San Francisco's remarkable features is its hills, and the grid pattern imposed upon them. Over time, builders in the City have responded to the challenge of dealing with sloping streets by stepping individual buildings up or down in a way that accentuates the unusual landforms. Present construction methods do not preclude a continuation of this practice, despite the fact that often its importance is not recognized and therefore not adhered to. When "stepping" rooflines, builders should note the incline of the slope and mimic its direction. One evident example of where this principle failed occurs on Elsie Street. In this case, two adjacent buildings were built with an effort at "stepping", but they step the wrong way. Whenever possible, new neighbors should try to coordinate their designs so that a naturally stepping skyline results.

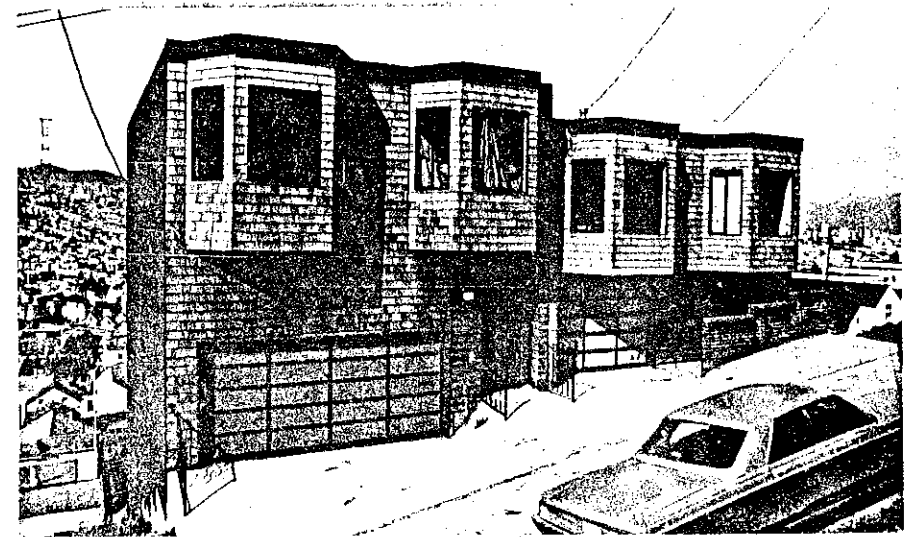

Two new buildings which do not step with the slope of the street.

FACADE ELEMENTS

In our attempt to analyze which architectural facade elements gave the Bernal Heights area its distinctive small-town, humanly-scaled character, we noticed a number of parts and relationships the use of which, in certain combinations, have come to serve as models for these Building Guidelines. This *guideline* recommends an approach to well-proportioned, sensitively-handled design rather than a prescription of what must be done or a restriction on what is not to be done.

INTENT

The intention here is to maximize the possibilities for diversity while striving for harmony between dissimilar pieces on neighboring buildings so that they fit into a satisfying whole. We support the Department of City Planning's policy from its document on Potential Development On or Near the Top of Hills that "buildings, when seen together, produce a *total* effect that characterizes the city and its districts." (Policy 3). Though in this section of the guidelines we are primarily concerned with the design of individual buildings, the impact of each on the overall effect of the whole area cannot be overlooked. Once again, from the same document, "To conserve design character in distinctive older areas, some uniformity of scale...is necessary." (Policy 4) One obvious difficulty in discerning the essence of the built form of the existing houses in the area is the way in which those forms are obscured by Victorian detailing. Recognizing that these decorative features are no longer available to builders of new structures, this effort tries to distill the form-giving elements that appear so pleasing and encourage the use of their modern counterparts in future construction.

Buildings can be viewed as aggregations of different architectural pieces. Bays, light wells, dormers, sideyards, terraces, decks, entry porches, and the like serve to break up the massing of the structure. They give the planar surfaces a three-dimensionality and diminish the likelihood of monolithic box forms. Maximum envelope boxes provide no sense of depth along the street and tend to make all landscaping linear. To quote once more from City Planning policy (Policy C3), "External details of buildings provide visual interest and enrichment and maintain the historic scale and texture of San Francisco."

Many properties have been pinpointed as being particularly noteworthy of attention. The following drawings of houses in the neighborhood serve as examples of both successful and less successful composites of design elements.

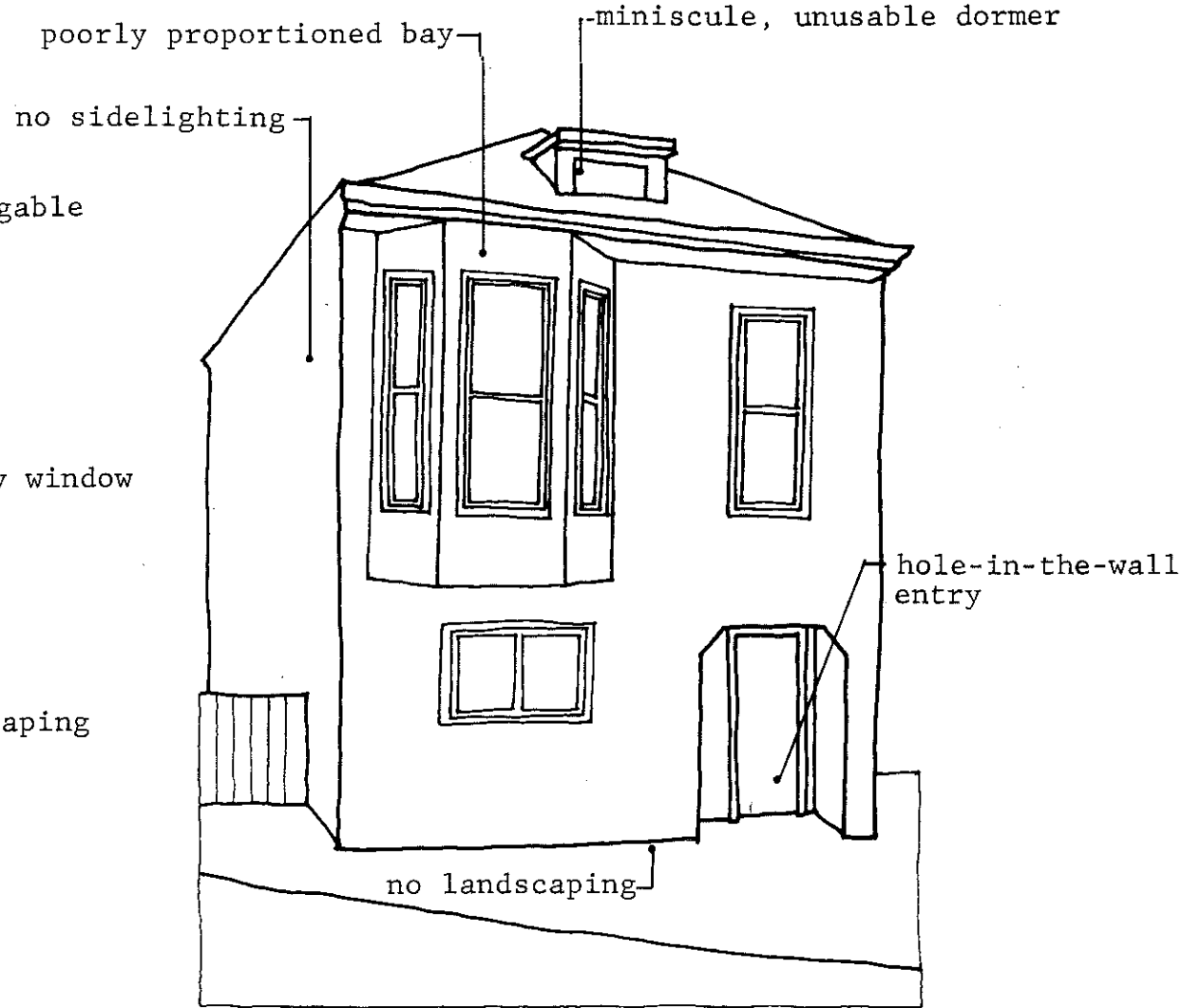
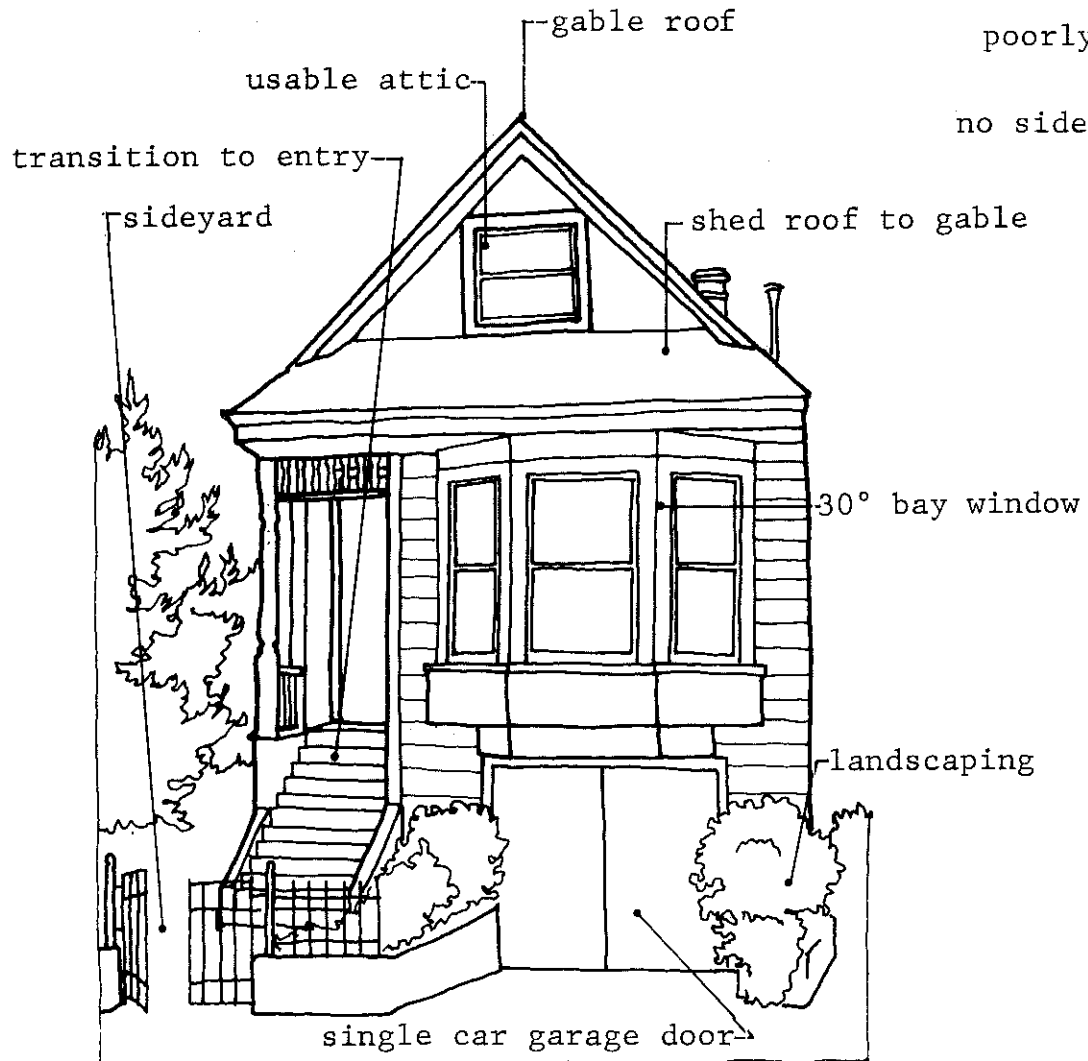

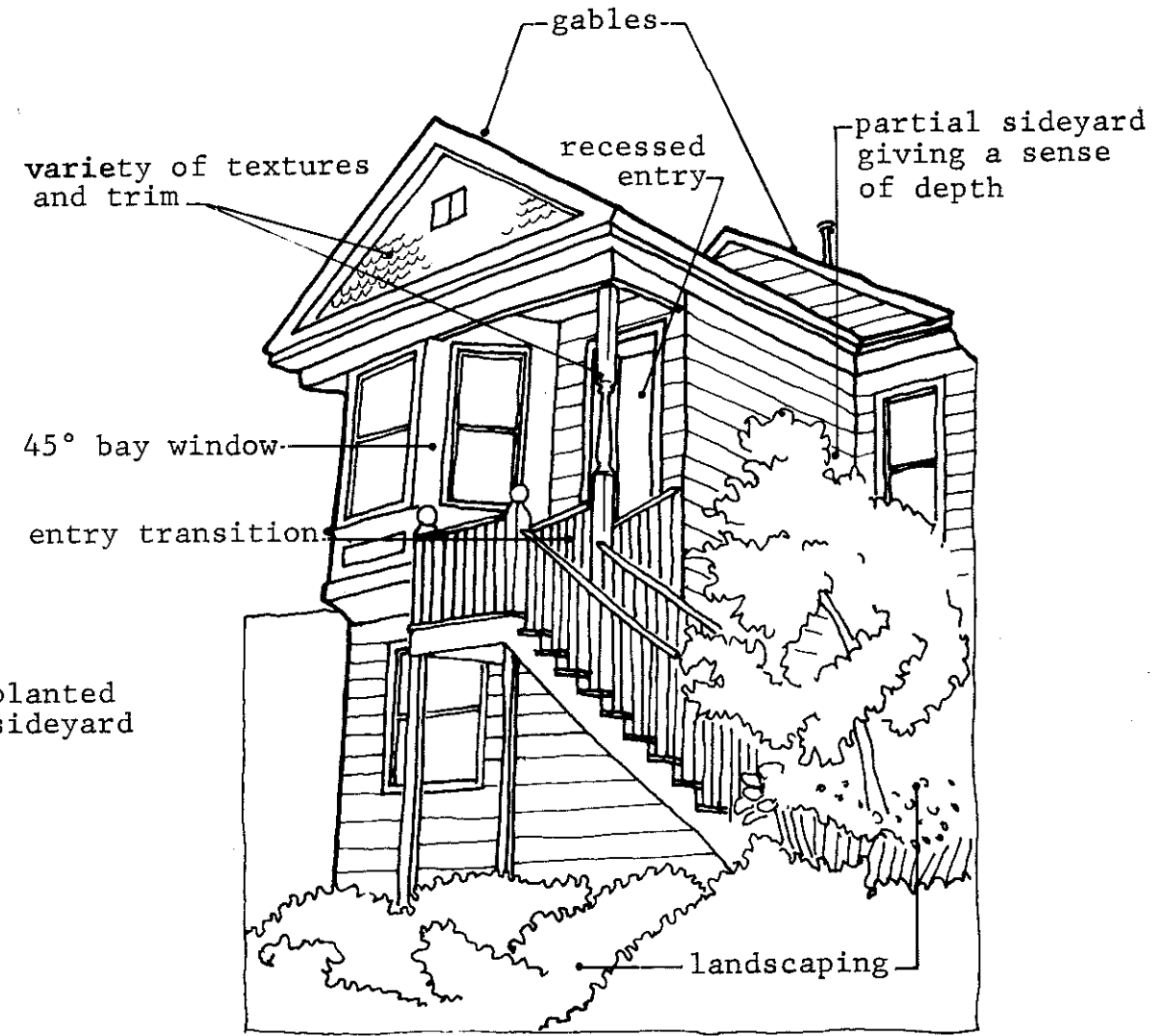
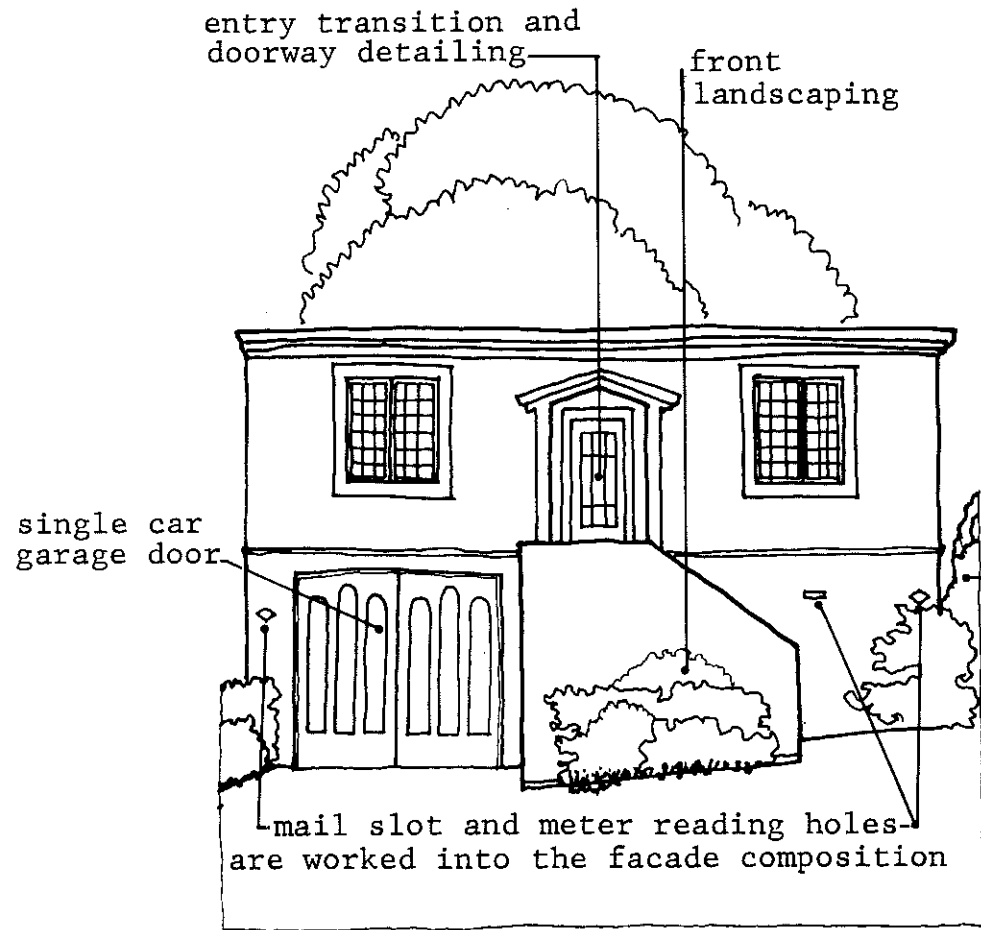

Optimally, in tackling the design of new buildings for the remaining lots on the East Slope, owners and builders will be able to interpret the spirit of these guidelines, which define the area's charm, in new and interesting ways. This involves more than merely tacking token saddlebag appendages onto box-like forms. Rather, it is hoped that the integrity of the interior flow of spaces would be reflected on the exterior, and that the shape would be determined from the inside moving out as well as vice versa. If this approach is taken, a maximum, lot-line to lot-line box would rarely, if ever, occur.

The variety of bay, entry, porch, window, roofline, and garage door treatments is infinite. Bays alone can be angled at 45 degrees, 30 degrees, 60 degrees, or whatever; they can be square or round-cornered; stacked, fluted, or double width; flat, or shed-roofed. Sunlight could enter through skylights, clerestories, lightwells or dormers, as well as via more standard framing treatments. Porches might be partially enclosed, windscreened, or sunscreened, trellised or not. The only "rule" that is included in this section, however, does pertain to decks and/or balconies. It has been found that those which are less than 6'-0" deep are hardly ever used and become simply symbols of what they are supposed to be. Therefore, any balcony above ground level must be at least 6'-0" deep and a minimum of 36 square feet in total area.

The following diagrams indicate how the maximum building bulk (as we have defined it under the "Sideyards" and "Bulk Limits" Guidelines) could be molded and shaped, with the thoughtful inclusion of elements such as bays, windows, decks, entries, and so on, to come up with a product which is in line with these guidelines and the existing houses in the surrounding neighborhood. It should be understood that these drawings are simply a few samples of the myriad possible approaches that can be taken in any given category of design elements. The resulting "put-together" products at the end are mere schematic representations and in no way actual suggestions of what *should* be done.

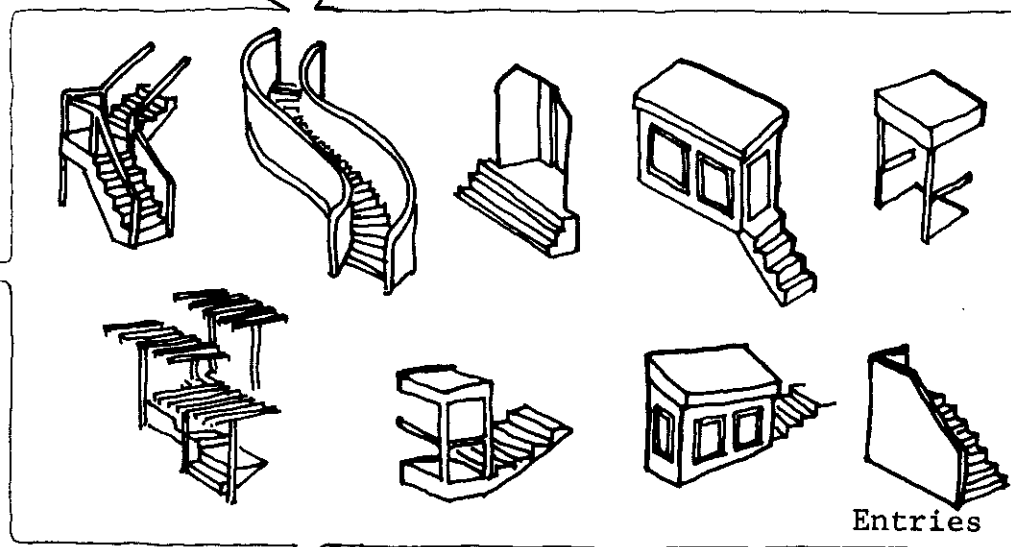
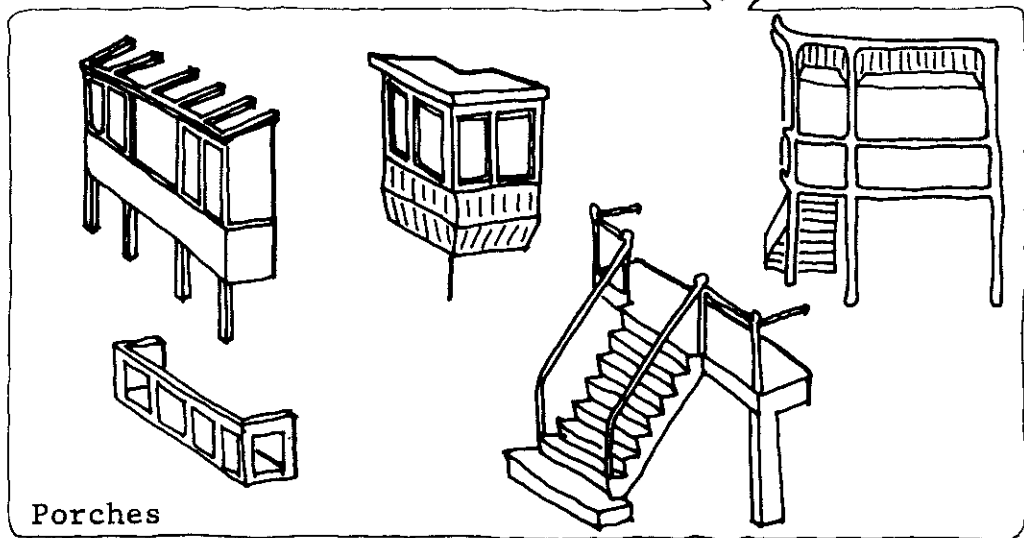
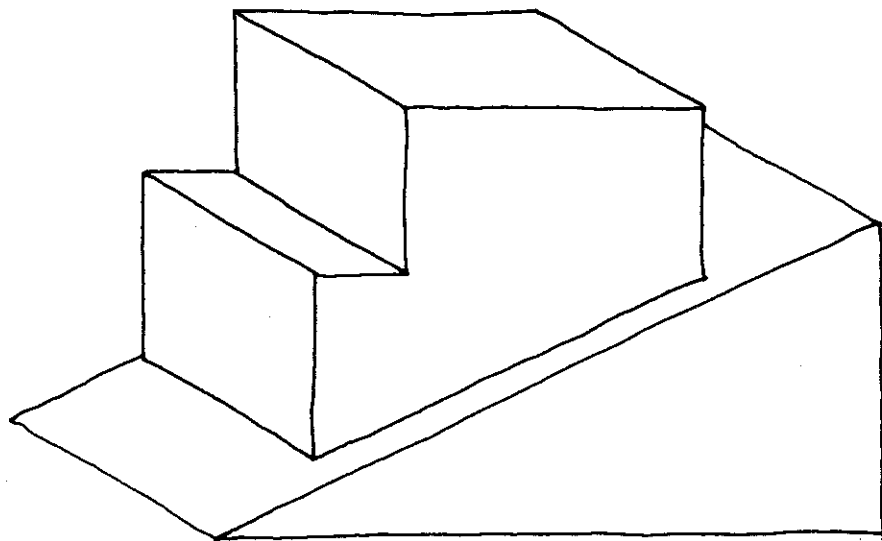

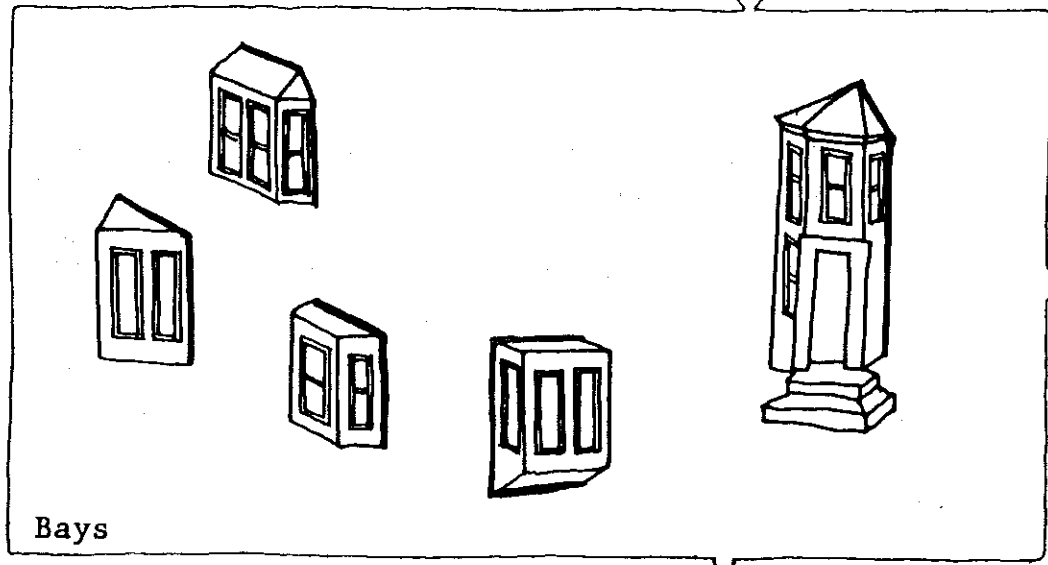

Bays

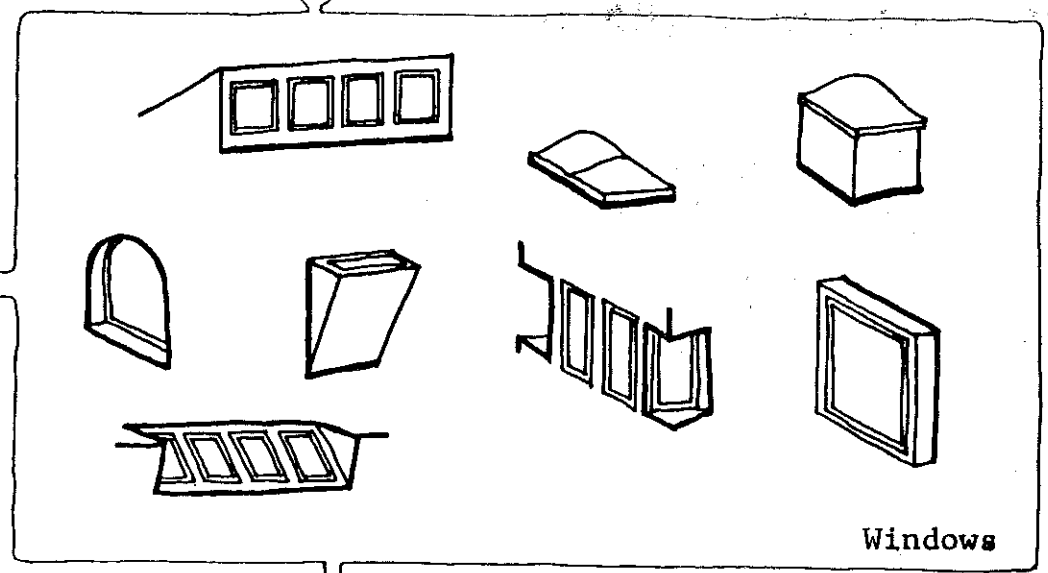

Windows

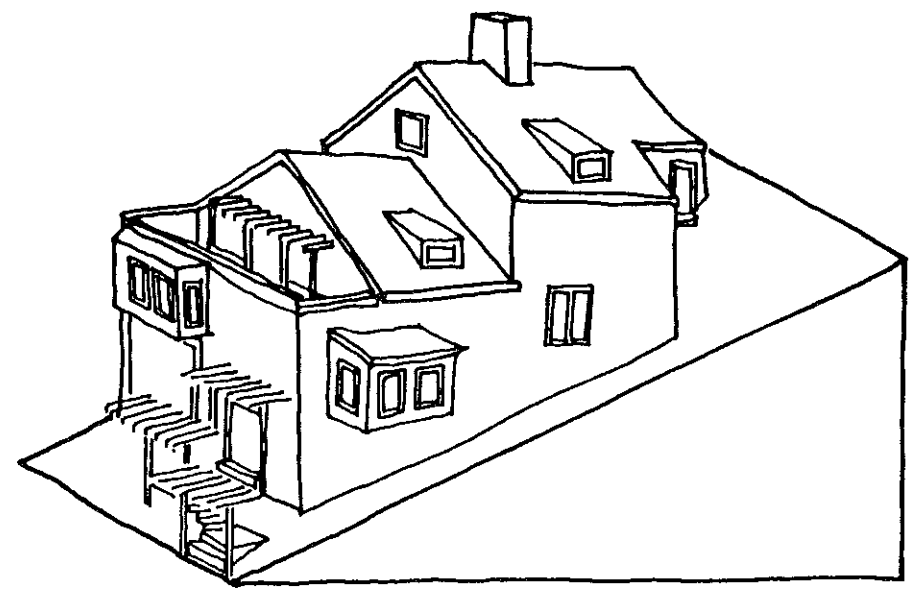

Upslope lot

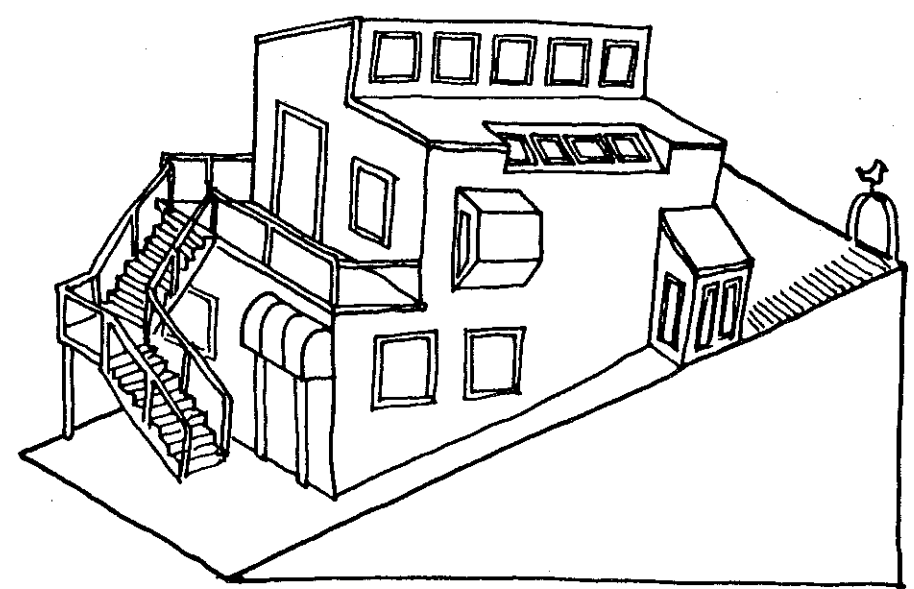

Downslope lot

COLORS & MATERIALS

Choosing the colors and materials to clothe the exterior of a new home is of course a very personal decision of the future owner. Determinations of what is attractive or "in good taste" are highly subjective and this study would not presume to dictate what they are. As the economics of today's building industry push many materials out of the realm of possibility, choices must be made on the basis of what is financially feasible as much as on any number of other considerations. On the other hand, a few observations and suggestions might prove helpful.

The neighborhood abounds in wonderful combinations of every material in the book. A tour around the area prior to final material selection should turn up any number of possibilities and would be worthwhile for any prospective homeowner.

Two specific materials which deserve a word of caution are stone veneers and plywood. It is very difficult to use a masonry veneer, alone or in combination, well. Plywood, because there are so many varieties available now, has become quite commonly acceptable as an exterior siding. It can be used very effectively if the detailing at the joints is dealt with. Flashing is needed between abutting sheets, but if it is left exposed and unpainted, often a raw or unfinished effect results.

As for color, it should be noted that light Mediterranean hues predominate in San Francisco. For homes on the East Slope which are to be painted, it seems particularly important to follow suit. Light shades reflect sunlight much more than dark ones do. Since so many East Slope streets are narrow, the more light that bounces back and forth the better. Additionally, we have a recommendation concerning the use of paint at the base of buildings. Where more than 1'-0" of a concrete foundation is exposed above grade on the front facade of a building, the concrete should be painted. If landscaping occurs at the base, of course this would not be necessary.

SUMMARY OF DESIGN GUIDELINES

1. 9'-0" CURB CUT/SINGLE CAR GARAGE DOOR:

Garage doors shall be limited to a 10'-0" width. Curb cuts shall be 9'-0" and placed so as to create a 16'-0" curb space within the 25'-0" width of the lot to provide one full parking space on the street. In addition, the garage door shall be placed a minimum of 16'-0" from the inside edge of the sidewalk so as to provide one additional parking space per residence in the driveway.

2. LANDSCAPING • FRONT YARD SETBACKS • STREET TREES

50% of the Front Yard Setback area (not including the driveway up to the garage) shall have provision for landscaping (i.e. trees, shrubs, flower beds, ground cover, vines, etc.).

One Street Tree shall be planted at the time of construction in front of each lot within the street right-of-way, and close to the front property line. Trees shall be 15-gallon size.

3. ENTRY TREATMENT

Make the entry of the house something special — a celebration — more than just a front door. Create a transition between the street and the doorway. Give special attention to the treatment of the framing of the opening itself.

Fences or walls which enclose a lot or a portion of a lot, which run parallel to the property line on the street side, and are not structural portions of the buildings or the stair leading to it, shall not be completely solid at eye level.

4. BUILDING AND ARCHITECTURAL MASSING

Step the building with the slope of the lot. Building shall not exceed 32'-0" from any point on natural grade. This height shall be measured to the average height of a pitched roof or to the highest point of a flat roof. In addition, no point of the last 10'-0" depth of the building may exceed 2/3 the height of the highest point of the structure. Highest point, once again, is defined as the average height of the pitch on a sloped roof or the highest point of a flat roof.

At the rear, a minimum 17'-6" rearyard is required.

5. SIDEYARDS

A 4'-0" sideyard is required on one side of each 25'-0" lot. The first 5'-0" back from the street facade shall be completely open. Beyond that, two of the four additional sideyard zones must be left open (See Guideline for discussion of "zones".)

6. ROOF TREATMENT • STEP WITH SLOPE ALONG STREET

Any roof which is not pitched at a ratio of at least one in four must be designed and surfaced so as to be usable.

Any flat roof must be accessible from a prime living space without the necessity of climbing a special set of stairs to reach it.

Step rooflines of adjacent buildings up or down in imitation of the slope of the street.

7. FACADE ELEMENTS

Any balcony, porch, deck or terrace above ground level must be at least 6'-0" deep and a minimum of 36 square feet in total area.

8. COLORS & MATERIALS

No specific guidelines but suggestions and recommendations.

DESIGN GUIDELINES CONCLUSION

There are a number of topics which need to be addressed and yet do not fit into the form of a guideline. The issue of security and crime is one of these. None of the guidelines deals with insuring the safety of a home. Nowhere do we mention the use of metal grills at the entry or the elimination of landscaping to cut down on the possible hiding places. In fact, on both social-psychological and aesthetic grounds, these measures are not encouraged. It has been proven that the isolation created when people live barricaded behind fortress-like walls stimulates incidents of criminal activity more than security systems deter them.

We do not believe that the solution to crime, particularly breaking and entering, is an architectural one. The long-term solution will only come from changes in society at large, with the best short-term defense being a cohesive, responsive community which looks out for and protects its members. The basis for this sort of open communication network among neighbors presently exists in this section of Bernal Heights, much as it has in small towns of old.

All of the guidelines assume the construction of one house per lot. Though not specifically encouraged, it would certainly be acceptable to build one house on two lots, especially when the topography of a site or the existence of trees made a portion of a given lot unusable. Several guidelines would have to be amended if applied to a double lot and this would be handled on a case-by-case basis, as the need arose.

The question of whether adherence to these guidelines would increase the construction costs of prospective new homes has often been raised. Since a major goal of this report is the maintenance of Bernal Heights as an area which is financially accessible to people of low and moderate incomes, there have been considerable concerns over this point. In an effort to arrive at an answer, many people in the construction business have been presented with our concepts and asked to try to assess, as nearly as possible, what the economic consequences might be. We have been assured to our satisfaction that our recommendations in and of themselves, would not impose undue financial burden on the developers and owners of new housing. There is nothing in the guidelines which call for a deviation from standard construction practice or necessitates the introduction of expensive architectural services. If, in the process of planning a new structure, one can demonstrate that compliance is significantly raising his or her costs for some unforeseen and irreconcilable reason, there would be grounds for proposing a compromise solution.

These guidelines have been developed because of specific conditions on the East Slope of Bernal Heights. They were mandated by the City Planning Department in conjunction with a temporary building moratorium. The guidelines were adapted from those successfully in use for the Elsie Street neighborhood in northwest Bernal Heights. Residents, vacant lot owners and representatives of several city departments contributed to the development of these guidelines.